



EN

Installation, Operation and Maintenance VENTUS Air-Handling Units Rated CFM from 800 to 8500

RECOGNIZED
COMPONENT



Conforms to UL Std 1995
Certified to CSA Std
C22.2 No. 236

Intertek
4009808

ventus



OMM-VTS-ver.1.06 (APR 2014)



Table of content

1	Warnings, Cautions and Notices	5
2	Model Descriptions	5
3	General Information	8
4	Pre-Installation	9
4.1	Receiving and Handling	9
4.1.1	Shipping Package	10
4.1.2	Ship-Separate Accessories	10
4.1.3	Receiving Checklist.....	10
4.1.4	Jobsite Storage Recommendation	11
4.2	Installation Preparation.....	11
4.2.1	Service Access.....	12
4.2.2	Rigging and Handling	12
4.2.3	Unit Location Recommendations.....	12
4.2.4	Skid Removal	12
4.3	Pre-Installation Checklist	13
5	Dimensions and Weights.....	13
5.1	Horizontal AHU.....	13
5.2	Horizontal AHU with Heat Wheel	16
5.3	Horizontal AHU with Cross-Flow Plate Exchanger.....	16
5.4	Vertical AHU.....	17
5.5	AHU components connection.....	19
5.5.1	Hydronic coil exchangers.....	19
5.5.2	Steam Coils	21
5.5.3	Electric Heaters	22
5.5.4	Air Filters	22
6	Installation: Controls	22
6.1	Installing Wall Mounted Control Box	22
6.2	Installing Control Elements	23
6.3	Installation of Variable Frequency Drive (Frequency Converter).....	28
7	Installation: Electrical	29
7.1	Unit Wiring Diagrams	29
7.2	Supply Power Wiring	29
7.3	Electrical Connections.....	30



7.4	Electrical Grounding Restrictions	30
7.5	Full Load Amps and Maximum Circuit Breaker.....	31
7.5.1	Electric Heater.....	31
7.5.2	Electric motor with frequency converter.....	32
7.6	Controller Wiring	35
7.7	Frequency Converter Wiring	37
8	Installation: Mechanical	39
8.1	Installing the Unit	39
8.2	Condensate Drain Connections	40
8.3	Duct Connections	42
9	Installation: Piping	42
9.1	Hydronic Coil Connections	42
9.2	Steam Piping.....	44
10	Controls Interface	45
10.1	Control Options.....	45
10.2	Control Interface	46
10.2.1	Control box with controller uPC	46
10.2.2	Advanced control panel HMI Advanced UPC	48
10.2.3	Simplified control panel - HMI Basic UPC	54
10.2.4	WEB-SERVER OPTION (TCP/IP Modbus).....	55
10.3	Controller Service Mode.....	55
11	Pre-Start.....	56
12	Start-Up	57
12.1	Sequence of Operation	57
12.2	UPC Controller Sequence of Operation.....	59
13	Maintenance	62
13.1	Maintenance Procedures.	62
13.2	Coil Maintenance	63
13.3	Heat recovery – heat wheel and cross-flow plate exchangers.	64
13.4	Periodic Maintenance Checklists	65
14	Troubleshooting	66
15	Wiring Diagrams	67
15.1	Connection the mains supply with frequency converters.	67
15.2	Connection of the mains supply with electric heater	70
16	Controls Diagrams.....	71



16.1	Application AS-1	72
16.2	Application AS-4	73
16.3	Application AS-5	74
16.4	Application AS-8	75
16.5	Applications AS 65-193.....	76
16.6	Applications AS 68-196.....	77
16.7	Applications AS 69-197.....	78
16.8	Applications AS 72-200.....	79
16.9	Applications AS 73-201.....	80
17	AHU's Technical Data Sheet	81



In-depth familiarization with the content of this manual, assembly, start-up and operation of the air handling unit in line with the instructions provided and following all safety regulations will ensure the basis of efficient, safe and non-failure operation of the device.

1 Warnings, Cautions and Notices

SAFETY WARNING!

- The installation, starting up, and servicing air handling units and their equipment can be hazardous and requires specific knowledge and training.
- Improperly installed, adjusted or altered equipment by an unqualified person could result in death or serious injury.
- When working on the equipment, observe all precautions in the literature and on the tags, stickers, and labels that are attached to the equipment.
- Only qualified personnel should install and service the equipment.

ATTENTION: Warnings, Cautions and Notices appear throughout this document. Read it carefully:

 **WARNING!** Indicates a potentially hazardous situation which, if not avoided, could result in death or serious injury.

 **CAUTION!** Indicates a potentially hazardous situation which, if not avoided, could result in minor or moderate injury. It could also be used to alert against unsafe practices.

 **NOTICE !** Indicates a situation that could result in equipment or property-damage only.

Personal Protective Equipment (PPE) Required!

- *Before installing/servicing this unit, technicians must put on all Personal Protective Equipment (PPE) recommended for the work being undertaken. Always refer to appropriate MSDS sheets and OSHA guidelines for proper PPE.*
- *When working with or around hazardous chemicals, ALWAYS refer to the appropriate MSDS sheets and OSHA guidelines for information on allowable personal exposure levels, proper respiratory protection and handling recommendations.*
- *If there is a risk of arc or flash, technicians MUST put on all Personal Protective Equipment (PPE) in accordance with NFPA 70E or other country-specific requirements for arc flash protection, PRIOR to servicing the unit.*

Failure to follow recommendations could result in death or serious injury.

2 Model Descriptions

The VENTUS air handling units of VTS family are draw-thru air handlers for cooling or/and heating load conditions of 800-8500 cfm. The units are available in either horizontal or vertical configurations. The vertical configurations are limited to 4500 cfm. Both types are typically floor mounted units. The horizontal devices can be suspended however the manufacturer does not fit the AHU with knockouts.

There is a list of symbols and functions of air handling units:

The horizontal AHU **VTS – XX - L/R – B***,
 The vertical AHU **VTS – XX - L/R – B*(v)**, where

- **VTS** → the product family,
- **XX** → the AHU sizes which are presented as the rounded rated air flow expressed in hundreds of CFM at 480 FPM (2,44 m/s) air velocity on coil.
 For exhaust, the unit size is equivalent to an AHU fitted with a coil.
- **L/R** → access (service) side, L – left, R – right
- **B*** → a symbol of a set of functions which are carried out in the device, where:
B* = B₁ – B – B₂
 - B₁ – the symbol of additional upstream functions in supply part of the AHU the symbol of basic (predefined) functions (an AHU's BASE). This function is fitted to the AHU outside its,
 - B – the symbol of predefined basic functions' set,
 - B₂ – the symbols of additional downstream functions fixed outside to the AHU casing ,

Table 1 Coding of functions









Symbol	Graphic	Function	Options of functions
F		Air filtration	Merv 8 (2") Merv 13 (4")
F- Base		Air filtration	External Box - Merv 8 (2") External Box - Merv 13 (4")
V		Ventilation	Motors' casing: OPSB, TEFC
C		Cooling (hydronic)	Rows: 3, 4, 6, 8
H		Heating (hydronic – water or steam)	Hot Water – rows: 1, 2 Steam – rows: 1
		Heating (electric)	Draw-through electric heater
Base-H		Heating (electric)	Blow-through electric heater (outside box)
M		Mixing (economizer)	In any direction of inlet
Pcr		Energy recovery system Plate cross-flow	Standard size with by-pass passage for each AHU size



Table 2 The coding system of vertical AHUs

Application		Main Function	Code of the main base (set of basic functions)	Functions*
Vertical AHU VTS 8-40 (V) (800-4000 CFM)	SUPPLY	Cooling	C(v)	F-CV
			MC(v)	MFCV
		Heating	H(v)	F-HV
			MH(v)	MFHV
		Heating and Cooling	HC(v)	F-HCV
			MHC(v)	MFHCV
			CH(v)	F-CHV
			CH(v)	F-CV-H
			MCH(v)	MFCHV

Table 3 The coding system of horizontal AHUs

Application		Main Function	Code of the main base (set of basic functions)	Functions*
HORIZONTAL AHU VTS 8-85 (800-8500 CFM)	SUPPLY	Cooling	C	FCV F-CV
			MC	MFCV
		Heating	H	FHV F-HV
			MH	MFHV
		Heating and Cooling	HC	FHCV
			MHC	MFHCV
			CH	FCHV
			CH	FCV-H
			MCH	MFCHV
		Exhaust	Ventilation	V
	FV			FV
	Supply Exhaust with energy recovery Cross-Flow Plate	Plate	P	FPcrV
		Plate and Cooling	PC	FPcrCV
			PC	FPcrCV
		Plate and Heating	PH	FPcrHV
			PH	FPcrHV
		Plate and Heating & Cooling	PHC	FPcrHCV
			PCH	FPcrCHV
	PCH		FPcrCV-H	

3 General Information

The VENTUS air handling units of VTS family are draw-thru air handlers for cooling or/and heating load conditions of 800-8500 cfm. The units are available in either horizontal or vertical configurations. The vertical configurations are limited to 4500 cfm. Both types are typically floor mounted units. The horizontal devices can be suspended, however the manufacturer does not fit the AHUs with knockouts.

⚠ WARNING! All VTS air handling units are intended for indoor use only!

The VTS air-handling units are intended for cooperation with a duct ventilation system. Thus access to the rotating parts of the unit (a fan's rotor) is impeded from both positive and negative pressure side of the unit. The ventilation duct system is understood as a net of ventilating ducts.

The majority of AHUs' configuration is available in left-hand access and right-hand access.

The version of the unit's access is determined by direction of the air flow against the inspection side of the unit (the side where the inspection panels are located). In case of supply-exhaust units the version is determined by the flow direction of the air through the supply section.

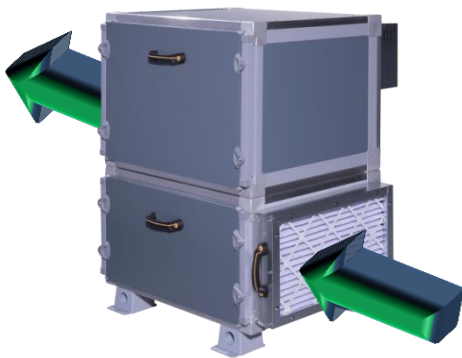

Fig. 1 Left-hand access

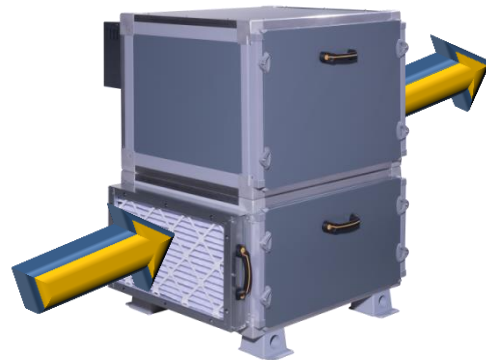

Fig. 2 Right-hand access

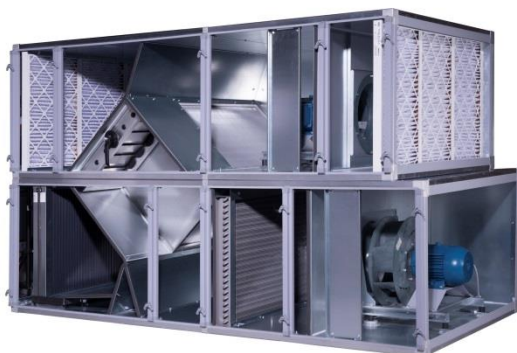

Fig. 4 Right-hand access (supply-exhaust AHU)



Fig. 3 Left-hand access (supply-exhaust AHU)

The units have a side inlet for easy duct connection, and do not require a field fabricated inlet plenum.

Basic unit components consist of a water coil, condensate drain pan (if applicable), filter, one direct drive fan assembly, frequency converters.

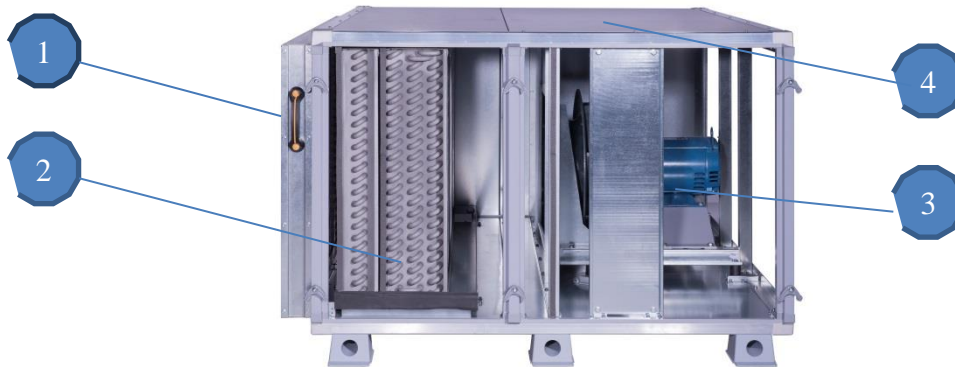

Fig. 5 Basic AHU construction: 1 – external filter, 2- coil exchangers , 3 – direct drive plenum fans, 4 – casing (PUR 1.57”)

Three, four, six, or eight-row main coils are available for hydronic cooling and one, two-row for heating. Three, four, or six-row direct expansion (DX) coils are also available for cooling. Also, a one-row preheat steam is available.

All units have an internal or external flat filter frame for two or four inch filters. All units are fitted with frequency converters as a standard.

Majority of units can have full-plenum inlet and/or outlet or small-plenum inlet and/or outlet (with face panel).

The units can be equipped with duct collars (flanges) on outlet and control system including (three-port valves with actuators, air dampers actuators, temperature sensors, anti-freeze elements, control box with controller, and control panel HMI (Human Machine Interface).

4 Pre-Installation

4.1 Receiving and Handling

The air handling units are packaged for easy handling and storage on the job site. Upon delivery, inspect all components for possible shipping damage. See the “Receiving Checklist” section for detailed instructions. VTS recommends leaving units and accessories in their shipping packages/skids for protection and handling ease until installation.

The devices should be unloaded and transported to the AHU’s installation site using a hand lift or forklift (fig.6) or a crane (fig.7).

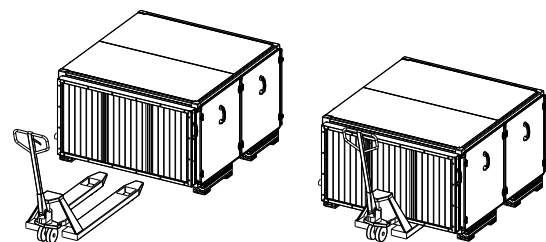
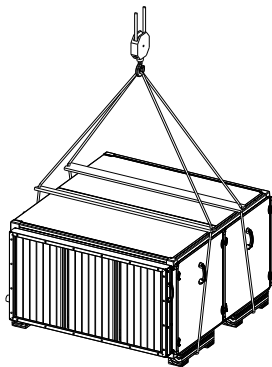

Fig. 6 Using a hand lift to transport the unit

Fig. 7 Transport with the use of a crane



The AHUs have to be transported in their working position and they shall not be stored one on the other.

4.1.1 Shipping Package

The air handling units ship assembled on skids with protective coverings over the coil, frequency converters and discharge openings.

4.1.2 Ship-Separate Accessories

Field-installed control elements (if applicable) ship separately inside a box.

4.1.3 Receiving Checklist

Complete the following checklist immediately after receiving unit shipment to detect possible shipping damage.

- Inspect individual cartons before accepting. Check for rattles, bent carton corners, or other visible indications of shipping damage.
- If a unit appears damaged, inspect it immediately before accepting the shipment. Manually rotate the fan wheel to ensure it turns freely. Make specific notations concerning the damage on the freight bill. Do not refuse delivery.
- Inspect the unit for concealed damage before it is stored and as soon as possible after delivery. Report concealed damage to the freight line within the allotted time after delivery. Check with the carrier for their allotted time to submit a claim.
- Do not move damaged material from the receiving location. It is the receiver's responsibility to provide reasonable evidence that concealed damage did not occur after delivery.
- Do not continue unpacking the shipment if it appears damaged. Retain all internal packing, cartons, and crate. Take photos of damaged material if possible.
- Notify the carrier's terminal of the damage immediately by phone and mail. Request an immediate joint inspection of the damage by the carrier and consignee.
- Notify your VTS representative of the damage and arrange for repair. Have the carrier inspect the damage before making any repairs to the unit.
- Compare the electrical data on the unit nameplate with the ordering and shipping information to verify the correct unit is received.



4.1.4 Jobsite Storage Recommendation

The devices are intended for indoor storage. If indoor storage is not possible, VTS company recommends the following provisions for outdoor storage:

- place the unit(s) on a dry surface, ensure adequate air circulation beneath unit and to assure that no portion of the unit contacts standing water at any time.
- cover the entire unit with a canvas tarp only. Do not use clear, black, or plastic tarps.

The units and their optional components should be stored in the following conditions:

- relative humidity in the room: RH < 80 % at DB temperature = 68°F
- ambient temperature: -40°F < DB temperature < +140°F
- the devices should be out of the reach of any caustic dust, gas or steam or

any other chemical substances which may have pro-corrosive influence on the unit and its components.

⊙ **NOTICE!** *Any damages caused by improper transportation, unloading or storage are not covered by the guarantee and any claims laid by way of aforementioned issues will not be examined by VTS.*

⊙ **NOTICE!** *Wet interior unit insulation can become an amplification site for microbial growth (mold), which may cause odors and health-related indoor air quality problems. If there is visible evidence of microbial growth (mold) on the interior insulation, remove and replace the insulation prior to operating the system.*

4.2 Installation Preparation

The **floor mounted unit** shall be placed on:

- a foundation slab,
- a steel base frame concreted into the floor,
- an appropriate stiff steelwork.

The foundation, steel base frame or steelwork have to be flat and leveled and they should be able to support the weight of the unit.

Verify the floor or foundation is level. Repair, if necessary. Make sure proper unit operation, install the unit level (zero tolerance) in both horizontal axes. Failure to level the unit properly can result in improper operation of the unit (e.g. condensate management problems, higher vibration level, lower heating/cooling capacity)

Provide adequate service clearances as recommended in this document.

The height of the foundation slab or base frame must allow for assembly of the P-trap which drains the condensate out of the draining tray. In case of the drain plates

installed in the lower AHU sections, the unit has to be mounted onto an additional foundation slab or a special hollow must be made directly under the P-trap. The minimum height of P-trap is given in the "Draining out condensate" section.

The height of the foundation slab or base frame must allow for assembly of the P-trap which drains the condensate out of the draining tray. In case of the drain plates installed in the lower AHU sections, the unit has to be mounted onto an additional foundation slab or a special hollow must be made directly under the P-trap. The minimum height of P-trap is given in the "Draining out condensate" section.

The **horizontal air handling** unit can be suspended.

Suspension of units requires external rigging which shall be field-mounted.

Ensure the ceiling opening is large enough for unit installation and maintenance requirements.

4.2.1 Service Access

The AHU shall be installed so that the connections of any related systems (ventilation ducts, pipelines, cabling, etc.) do not collide with the inspection panels.

In order to carry out the operation and maintenance successfully, please keep minimum recommended clearance (Fig.8) between the front side and existing construction elements (walls, pillars, pipelines, etc.)

This is possible to install other systems, pipelines, pillars in the operation area only if they will not hinder the maintenance and service procedures.

The coils are connected on the backside of the unit. The frequency converters are also factory mounted on the backside of the AHU. Please keep at least 20 inch clearance on the backside of the AHU.

⚠ CAUTION! *It is forbidden to place any elements on the AHU as well as use the AHU as a support of ventilation ducts and any other building components.*

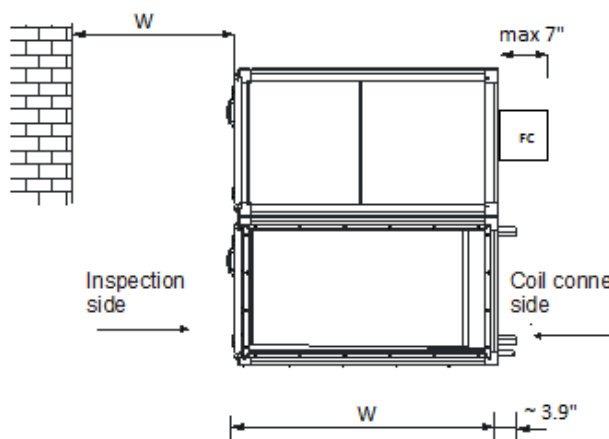

Fig. 8 Free space in the front area - the VTS 8-85 AHU

4.2.2 Rigging and Handling

Before preparing the unit for lifting, estimate the approximate center of gravity for lifting safety. Because of placement of internal components, the unit weight may be unevenly distributed, with more weight in the coil area.

Approximate unit weights are given in the technical data of AHU and device's nameplate'. Before hoisting the unit into position, use a proper rigging method such as straps, slings, or spreader bars for protection and safety. Always test-lift the unit to determine the exact unit balance and stability before hoisting it to the installation location.

Unit Handling Procedure

1. Position rigging sling under wood skid using spreader bars to avoid unit damage.
2. Use a forklift with caution to prevent unit damage. The fork length must be at least 85 inches long to safely fork the unit from front or back.
3. The unit center of gravity will fall within the center of gravity block at various locations depending on unit options.

4.2.3 Unit Location Recommendations

When selecting and preparing the unit installation location, consider the following recommendations.

1. Consider the unit weight. Reference the unit weight on the unit nameplate
2. Allow sufficient space for the recommended clearances, access panel removal, and maintenance access.
3. The installer must provide external rigging for ceiling mounted units.
4. All units must be installed level.
5. Coil piping and condensate drain requirements must be considered.

Allow room for proper ductwork and electrical connections. Support all piping and ductwork independently of unit to prevent excess noise and vibration.

4.2.4 Skid Removal

The unit ships on skids that provide forklift locations from the front or rear. The skid allows easy maneuverability of the unit during storage and transportation. Remove the skids before placing the unit in its permanent location. Remove the skids using a forklift or jack. Lift one end of the unit off of the skids.

4.3 Pre-Installation Checklist

Complete the following checklist before beginning unit installation.

- Verify the unit size and tagging with the unit nameplate.
- Make certain the floor or foundation is level, solid, and sufficient to support the unit and accessory weights. Refer to devices's nameplate.
- Level or repair the floor before positioning the unit if necessary.
- Allow minimum recommended clearances for routine maintenance and service. Refer to unit submittals for dimensions.
- Allow one and one half fan diameters above the unit for the discharge ductwork.

5 Dimensions and Weights

Data of weights is given in the AHU nameplate and technical data that is available in the VTS selection software.

5.1 Horizontal AHU

Height and width

Table 4 Basic dimensions of horizontal AHUs

VTS	W [in]	H [in]	W int [in]	H int [in]
8	27.2	20.8	24.0	14.5
12	37.8	20.8	34.7	14.5
16	43.4	22.8	40.3	16.5
20	46.0	26.0	42.8	19.7
30	52.7	31.3	49.6	25.0
40	58.3	36.0	55.1	29.7
55	65.4	40.0	62.2	33.7
65	74.4	41.4	71.3	35.1
85	82.1	45.4	78.9	39.1

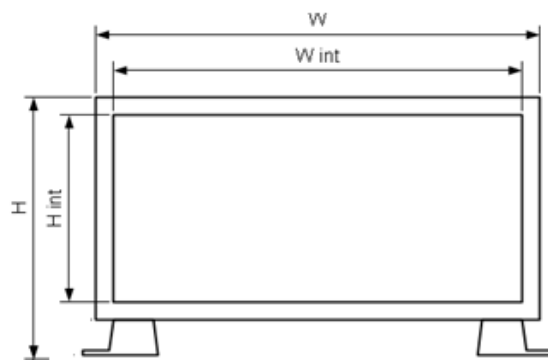

The length “L” of base of AHU’s is presented below in the tables below.

Table 5 The length “L” of base of AHU (Exhaust)

BASE	Code	Base's version*	VTS 8	VTS 12	VTS 16	VTS 20	VTS 30	VTS 40	VTS 55	VTS 65	VTS 85
FV	FV	FV	29.9	29.9	36.2	44.3	44.3	44.3	50.6	50.6	50.6
		FV_fp	36.2	36.2	36.2	44.3	50.6	50.6	50.6	58.7	58.7
	F-V	F-V	29.9	29.9	29.9	36.2	36.2	44.3	44.3	44.3	44.3
		F-V_fp	29.9	29.9	36.2	36.2	44.3	44.3	50.6	50.6	50.6
		F-V_st1	29.9	29.9	29.9	29.9	29.9	36.2	44.3	44.3	44.3
V	V	V	29.9	29.9	29.9	36.2	36.2	44.3	44.3	44.3	44.3
		V_fp	29.9	29.9	36.2	36.2	44.3	44.3	50.6	50.6	50.6



Table 6 The length “L” of base of AHU (cooling and cooling and reheating)

BASE	Code	Base's version*	VTS 8	VTS 12	VTS 16	VTS 20	VTS 30	VTS 40	VTS 55	VTS 65	VTS 85	
C	F-C	F-CV	36.2	36.2	44.3	44.3	50.6	50.6	58.7	58.7	58.7	
		F-CV_fp	36.2	44.3	44.3	50.6	50.6	58.7	58.7	58.7	58.7	
		F-CV_st1	36.2	36.2	36.2	36.2	44.3	44.3	44.3	50.6	50.6	
		F-CV_st2	36.2	36.2	36.2	36.2	44.3	44.3	44.3	50.6	50.6	
	C	CV	36.2	36.2	44.3	44.3	50.6	50.6	58.7	58.7	58.7	58.7
		CV_fp	36.2	44.3	44.3	50.6	50.6	58.7	58.7	58.7	58.7	58.7
		FCV	44.3	44.3	50.6	50.6	58.7	58.7	58.7	65.0	65.0	65.0
		FCV_fp	44.3	44.3	50.6	58.7	58.7	58.7	58.7	65.1	73.1	65.0
CH	C-H	FCV-H	44.3	44.3	50.6	58.7	58.7	58.7	65.2	73.1	65.0	
	CV-H	CV-H	36.2	44.3	44.3	50.6	50.6	58.7	58.7	58.7	58.7	
	F-CH	F-CHV	44.3	44.3	44.3	50.6	50.6	58.7	58.7	65.0	65.0	
		F-CHV_fp	44.3	44.3	50.6	50.6	58.7	58.7	65.0	73.1	65.0	
		F-CHV_st1	36.2	36.2	36.2	44.3	44.3	50.6	50.6	58.7	58.7	
		F-CHV_st2	36.2	36.2	44.3	44.3	44.3	50.6	58.7	65.0	58.7	
	F-C-H	F-CV-H	36.2	44.3	44.3	50.6	50.6	58.7	58.7	58.7	58.7	
	CH	CHV	44.3	44.3	44.3	50.6	50.6	58.7	58.7	65.0	65.0	
		CHV_fp	44.3	44.3	50.6	50.6	58.7	58.7	65.0	73.1	65.0	
		FCHV	44.3	50.6	50.6	58.7	58.7	58.7	65.0	65.0	65.0	
		FCHV_fp	44.3	50.6	50.6	58.7	65.0	65.0	65.0	73.1	73.1	

Table 7 The length “L” of base of AHU (heating and heating & cooling)

BASE	Code	Base's version*	VTS 8	VTS 12	VTS 16	VTS 20	VTS 30	VTS 40	VTS 55	VTS 65	VTS 85	
H	H	FHV	36.2	44.3	44.3	44.3	50.6	50.6	58.7	58.7	58.7	
		FHV_fp	44.3	44.3	44.3	50.6	50.6	58.7	58.7	58.7	58.7	
		HV	36.2	36.2	44.3	44.3	44.3	44.3	50.6	50.6	50.6	
		HV_fp	36.2	44.3	44.3	44.3	50.6	50.6	50.6	58.7	58.7	
	F-H	F-HV	36.2	36.2	44.3	44.3	44.3	44.3	44.3	50.6	50.6	50.6
		F-HV_fp	36.2	44.3	44.3	44.3	50.6	50.6	50.6	58.7	58.7	
HC	F-HC	F-HCV	44.3	44.3	44.3	50.6	50.6	58.7	58.7	65.0	65.0	
		F-HCV_fp	44.3	44.3	50.6	50.6	58.7	58.7	65.0	73.1	65.0	
		F-HCV_st1	36.2	36.2	36.2	44.3	44.3	50.6	50.6	58.7	58.7	
		F-HCV_st2	36.2	36.2	44.3	44.3	44.3	50.6	58.7	65.0	58.7	
	HC	FHCV	44.3	50.6	50.6	58.7	58.7	58.7	65.0	65.0	65.0	
		FHCV_fp	44.3	50.6	50.6	58.7	65.0	65.0	65.0	73.1	73.1	
		HCV	44.3	44.3	44.3	50.6	50.6	58.7	58.7	65.0	65.0	
		HCV_fp	44.3	44.3	50.6	50.6	58.7	58.7	65.0	73.1	65.0	

Table 8 The length “L” of base of AHU with mixing chamber (economizer)

BASE	Code	Base's version*	VTS 8	VTS 12	VTS 16	VTS 20	VTS 30	VTS 40	VTS 55	VTS 65	VTS 85
MC	MC	MFCV	58.7	58.7	65.0	65.0	65.0	73.1	87.5	87.5	93.7
		MFCV_fp	58.7	58.7	65.0	73.1	73.1	73.1	93.7	93.7	101.9
		MFCV_st1	50.6	50.6	50.6	58.7	58.7	65.0	73.1	79.4	79.4
		MFCV_st2	50.6	50.6	58.7	58.7	58.7	65.0	79.4	79.4	87.5
MCH	MC-H	MFCV-H	58.7	58.7	65.0	73.1	73.1	73.1	93.7	93.7	101.9
	MCH	MFCHV	58.7	65.0	65.0	73.1	73.1	73.1	87.5	93.7	93.7
		MFCHV_fp	65.0	65.0	65.0	73.1	79.4	79.4	101.9	101.9	101.9
		MFCHV_st1	58.7	58.7	58.7	58.7	58.7	65.0	79.4	87.5	87.5
MH	MH	MFCHV_st2	58.7	58.7	58.7	58.7	65.0	65.0	87.5	93.7	87.5
		MFHV	50.6	58.7	58.7	58.7	65.0	65.0	79.4	79.4	87.5
MHC	MHC	MFHV_fp	58.7	58.7	58.7	65.0	65.0	73.1	87.5	87.5	87.5
		MFHCV	58.7	65.0	65.0	73.1	73.1	73.1	87.5	93.7	93.7
		MFHCV_fp	65.0	65.0	65.0	73.1	79.4	79.4	101.9	101.9	101.9
		MFHCV_st1	58.7	58.7	58.7	58.7	58.7	65.0	79.4	87.5	87.5
MHC	MHC	MFHCV_st2	58.7	58.7	58.7	58.7	65.0	65.0	87.5	93.7	87.5

* The versions of bases refer to configuration and equipment:

- fp – refers to air discharge other than FORWARD-FULL,

- st1 and st2 refer to options: air discharge FORWARD-FULL, filters -MERV8, motor's casing OPSB, and coil exchangers which are mentioned in the table below

Table 9 The rules of St1 and St2 versions of bases selections (Tab. 6,7,8)

Base's version	Water Coil Cooler's row number	Hot Water Coil Exchanger
V_h_st1	-	-
F-CV_h_st1	4R	-
F-CV_h_st2	6R	-
F-CHV_h_st1	4R	1R, 2R
F-CHV_h_st2	6R	1R, 2R
F-HCV_h_st1	4R	1R, 2R
F-HCV_h_st2	6R	1R, 2R
MFCV_h_st1	4R	-
MFCV_h_st2	6R	-
MFCHV_h_st1	4R	1R, 2R
MFCHV_h_st2	6R	1R, 2R
MFHCV_h_st1	4R	1R, 2R
MFHCV_h_st2	6R	1R, 2R

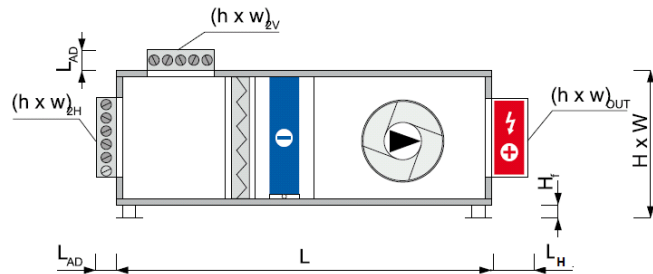

Fig. 9 Dimensions of AHU with external electric heater; $L_{AD} = 4.92$, $L_H = 7$

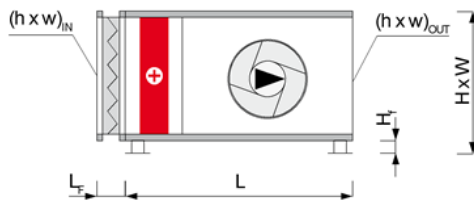

Fig. 10 Dimensions of AHU with external filter box; $L_F = 3.3$

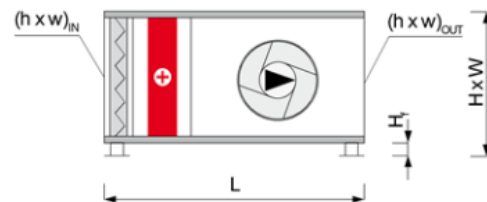

Fig. 11 Dimensions of AHU with embedded filter.

Inlet, discharge holes

Table 10 Dimensions of Forward-Full Inlet-Outlet holes

SIZE	Forward-Full	
	Inlet h x w [in]	Discharge h x w [in]
VTS-8	20.87 x 11.34	20.87 x 11.34
VTS-12	31.54 x 11.34	31.54 x 11.34
VTS-16	37.13 x 13.39	37.13 x 13.39
VTS-20	39.69 x 16.54	39.69 x 16.54
VTS-30	46.42 x 21.86	46.42 x 21.86
VTS-40	51.97 x 26.58	51.97 x 26.58
VTS-55	59.06 x 30.52	59.06 x 30.52
VTS-65	68.15 x 31.97	68.15 x 31.97
VTS-85	75.79 x 35.95	75.79 x 35.95

Dimensions of inlet-outlet holes						
A	A1	B	B1	B2	C	C1
[in]						
18	4.6	8	4.8	3.5	11	3.3
26	5.9	8	4.8	3.5	11	3.3
34	4.7	8	5.8	3.5	13	3.3
26	10.0	12	5.4	3.5	16	3.4
34	9.4	12	8.1	3.5	21	3.6
48	5.1	12	10.4	3.5	21	5.9
48	8.7	16	10.4	3.5	30	3.4
60	7.2	16	11.1	3.5	30	4.1
60	11.0	20	11.1	3.5	35	3.6

Fig. 12 Inlet, discharge (outlet) holes other than forward-full

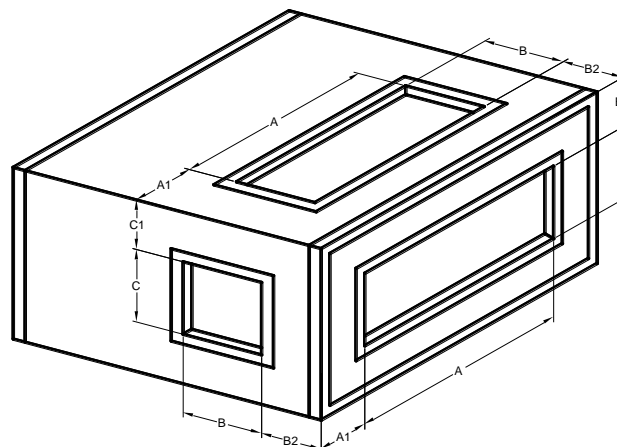

5.2 Horizontal AHU with Heat Wheel

Table 11 Basic dimensions of horizontal AHUs with energy recovery system [inches]

VTS	H ₂	W	W _{int}	H _{int}
12	38.4	37.8	34.7	14.5
16	42.5	43.4	40.3	16.5
20	48.8	46.0	42.8	19.7
30	59.4	52.7	49.6	25.0
40	68.9	58.3	55.1	29.7
55	76.8	65.3	62.2	33.7
65	79.7	74.4	71.3	35.1

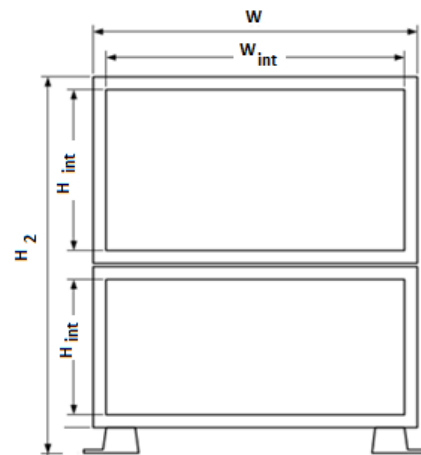

The lengths and weights of devices are available in the selection software on www.vtsgroup.com.

5.3 Horizontal AHU with Cross-Flow Plate Exchanger

The VTS air handling units can be equipped with rotary wheel (rotary regenerator) or cross-flow plate exchanger.

VTS	H ₂	W	W _{int}	H _{int}
8	38.4	27.2	24.0	14.5
12	38.4	37.8	34.7	14.5
16	42.5	43.4	40.3	16.5
20	48.8	46.0	42.8	19.7
30	59.4	52.7	49.6	25.0
40	68.9	58.3	55.1	29.7
55	76.8	65.3	62.2	33.7
65	79.7	74.4	71.3	35.1
85	87.6	82.1	78.9	39.1

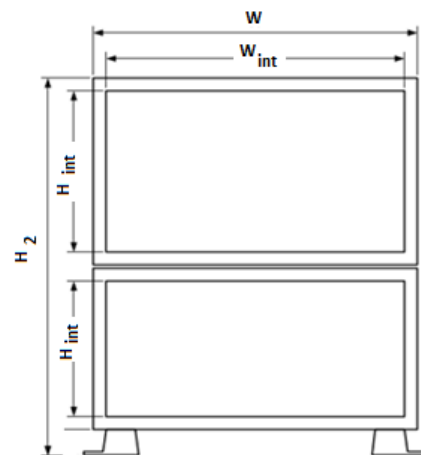

5.4 Vertical AHU

Height and width

Table 12 Basic dimensions of vertical AHUs [inches]

VTS	W	H ₂	W _{int}	H _{d int}	H _{u int}
8	27.2	43.6	24.0	14.5	19.7
12	37.8	43.6	34.7	14.5	19.7
16	43.4	45.7	40.3	16.5	19.7
20	46.0	54.1	42.8	19.7	25.0
30	52.7	59.4	49.6	25.0	25.0
40	58.3	68.9	55.1	29.7	29.7

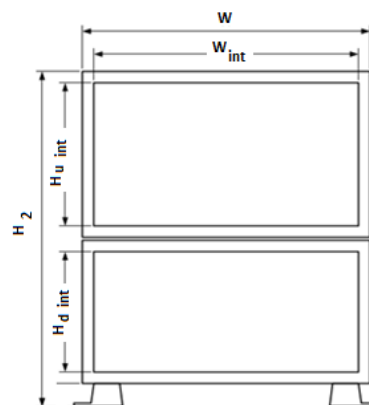

Table 13 The length “L” [inches] of base of vertical AHUs

BASE	Code	Base's version*	VTS 8	VTS 12	VTS 16	VTS 20	VTS 30	VTS 40	
C (v)	F-C (v)	F-CV_v	29.9	29.9	29.9	29.9	29.9	29.9	
		F-CV_v_st1	29.9	29.9	29.9	29.9	29.9	29.9	
		F-CV_v_fp	29.9	29.9	29.9	29.9	29.9	29.9	
CH (v)	F-CH (v)	F-CHV_v	29.9	29.9	29.9	29.9	29.9	29.9	
		F-CHV_v_fp	29.9	29.9	29.9	29.9	29.9	29.9	
		F-CHV_v_st1	29.9	29.9	29.9	29.9	29.9	29.9	
	F-C-H (v)	F-CV-H_v	29.9	29.9	29.9	29.9	29.9	29.9	
H (v)	F-H (v)	F-HV_v	29.9	29.9	29.9	29.9	29.9	29.9	
		F-HV_v_fp	29.9	29.9	29.9	29.9	29.9	29.9	
HC (v)	F-HC (v)	F-HCV_v	29.9	29.9	29.9	29.9	29.9	29.9	
		F-HCV_v_fp	29.9	29.9	29.9	29.9	29.9	29.9	
		F-HCV_v_st1	29.9	29.9	29.9	29.9	29.9	29.9	
MC (v)	MC (v)	MFCV_v	50.6	50.6	50.6	58.7	58.7	58.7	
		MFCV_v_fp	50.6	50.6	50.6	58.7	58.7	58.7	
		MFCV_v_st1	50.6	50.6	50.6	58.7	58.7	58.7	
MCH (v)	MC (v)-H	MFCV-H_v	50.6	50.6	50.6	58.7	58.7	58.7	
		MCH (v)	MFCHV_v	50.6	50.6	50.6	58.7	58.7	58.7
			MFCHV_v_fp	50.6	50.6	50.6	58.7	58.7	58.7
MFCHV_v_st1	50.6		50.6	50.6	58.7	58.7	58.7		
MH (v)	MH (v)	MFHV_v	50.6	50.6	50.6	58.7	58.7	58.7	
		MFHV_v_fp	50.6	50.6	50.6	58.7	58.7	58.7	
MHC (v)	MHC (v)	MFHCV_v	50.6	50.6	50.6	58.7	58.7	58.7	
		MFHCV_v_fp	50.6	50.6	50.6	58.7	58.7	58.7	
		MFHCV_v_st1	50.6	50.6	50.6	58.7	58.7	58.7	

* The versions of bases refer to configuration and equipment:

- **fp** – refers to air discharge other than FORWARD-FULL,
- **st1** and **st2** refer to options: air discharge FORWARD-FULL, filters -MERV8, motor's housing OPSB, and coil exchangers which are mentioned in the table below.

Table 14 The rules of St1 and St2 versions of bases selections

Base's version	Water Coil Cooler's row number	Hot Water Coil Exchanger
F-CV_v_st1	4R, 6R	-
F-CHV_v_st1	4R	1R, 2R
F-HCV_v_st1	4R	1R, 2R
MFCV_v_st1	4R, 6R	-
MFCHV_v_st1	4R	1R, 2R

Inlet holes are the same as in the vertical units..

Outlet discharge holes

Dimensions of Forward-Full Inlet-Outlet holes.

Table 15 Dimensions of Forward-Full Inlet-Outlet holes

AHU Size	Forward-Full Inlet	Forward-Full Discharge Holes
	h x w [in]	h x w [in]
VTS- 8 (v)	20.87 x 11.34	20.87 x 16.54
VTS-12 (v)	31.54 x 11.34	31.54 x 16.54
VTS-16 (v)	37.13 x 13.39	37.13 x 16.54
VTS-20 (v)	39.69 x 16.54	39.69 x 21.86
VTS-30 (v)	46.42 x 21.86	46.42 x 21.86
VTS-40 (v)	51.97 x 26.58	51.97 x 26.58

Table 16 Dimensions and layout of Inlet/outlet holes in vertical units

VTS	A	A1	B	B1	B2	C	C1
	[in]						
8	18	4.6	8	4.5	10.9	11	9.4
12	26	5.9	8	4.5	10.9	11	9.4
16	34	4.7	8	5.0	10.9	13	8.4
20	26	10	12	5.0	8.9	16	6.9
30	34	9.4	12	5.0	8.9	21	4.4
40	48	5.1	12	5.0	8.9	21	4.4

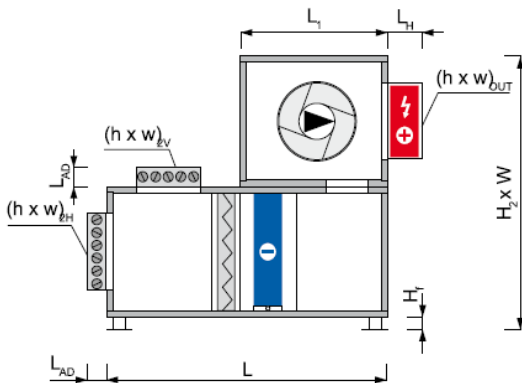
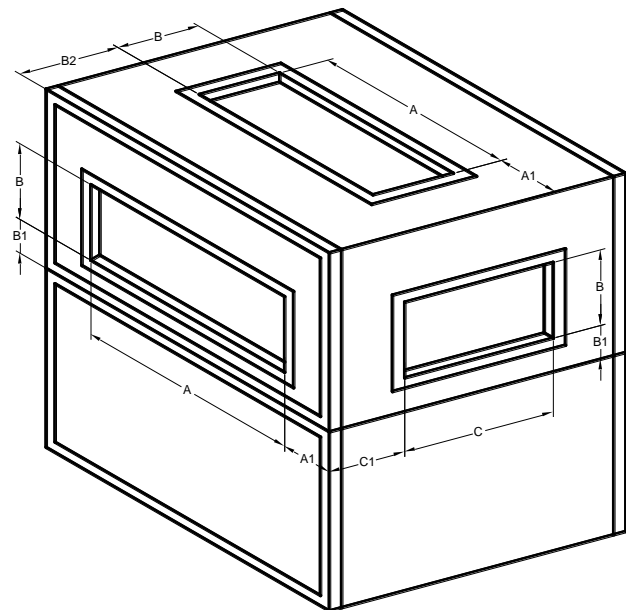

Fig. 13 Dimensions of vertical AHU with external electric heater LAD = 4.92,

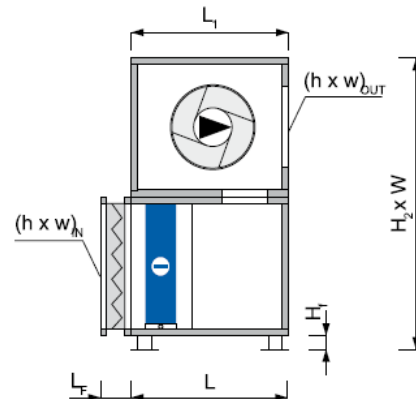

Fig. 14 Dimensions of vertical AHU with external filter LF = 3.3

5.5 AHU components connection

5.5.1 Hydronic coil exchangers

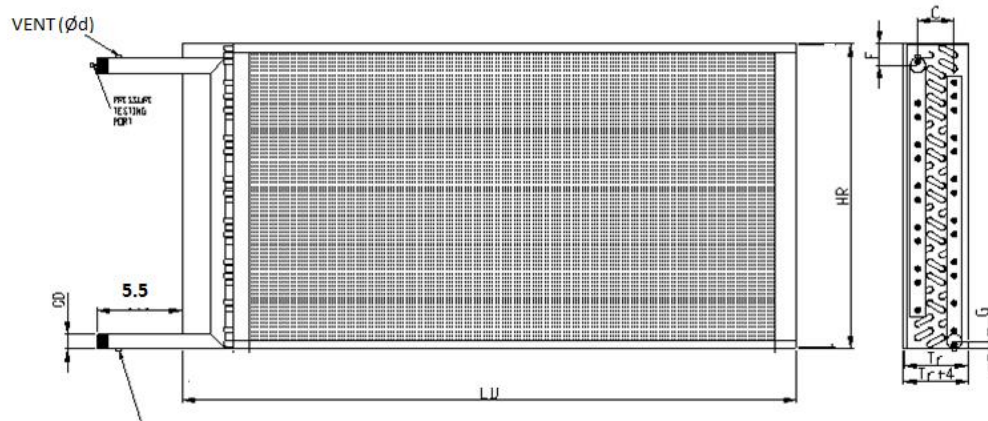

Fig. 15 Dimensions of hydronic coil exchangers

Table 17 Dimensions of hydronic coil exchangers of VTS 8-12 (Fig. 15)

VTS code	LD	HR	C	F	G	TR	OD	Ød
VTS 8 1R	23.7	12.6	2.4	1.7	0.6	4.3	3/4"	1/8"
VTS 8 2R	23.7	12.6	2.4	1.7	0.6	4.3	3/4"	1/8"
VTS 8 3R	23.7	12.6	3.2	1.7	0.6	5.7	3/4"	1/8"
VTS 8 4R	23.7	12.6	3.2	1.7	0.6	5.7	3/4"	1/8"
VTS 8 6R	23.7	12.6	5.4	1.8	0.7	7.5	3/4"	1/8"
VTS 8 8R	23.7	12.6	7.6	1.8	0.7	9.8	3/4"	1/8"
VTS 12 1R	34.4	12.6	2.3	1.8	0.7	4.3	1"	1/8"
VTS 12 2R	34.4	12.6	2.3	1.8	0.7	4.3	1"	1/8"
VTS 12 3R	34.4	12.6	3.2	1.8	0.7	5.7	1"	1/8"
VTS 12 4R	34.4	12.6	3.2	1.8	0.7	5.7	1"	1/8"
VTS 12 6R	34.4	12.6	5.4	1.8	0.7	7.5	1"	1/8"
VTS 12 8R	34.4	12.6	7.6	1.8	0.7	9.8	1"	1/8"

Table 18 Dimensions of hydronic coil exchangers of VTS 16-20 (Fig. 15)

VTS code	LD	HR	C	F	G	TR	OD	Ød
VTS 16 1R	34.8	14.6	2.3	1.8	1.6	4.3	1"	1/8"
VTS 16 2R	34.8	14.6	2.3	1.8	1.6	4.3	1"	1/8"
VTS 16 3R	34.8	14.6	3.2	1.8	1.6	5.7	1"	1/8"
VTS 16 4R	34.8	14.6	3.2	1.8	1.6	5.7	1"	1/8"
VTS 16 6R	34.8	14.6	5.4	1.9	1.9	8.5	1 1/4"	1/4"
VTS 16 8R	34.8	14.6	7.6	1.9	1.9	9.8	1 1/4"	1/4"
VTS 20 1R	42.5	17.6	2.3	1.8	0.7	4.3	1"	1/8"
VTS 20 2R	42.5	17.6	2.3	1.8	0.7	4.3	1"	1/8"
VTS 20 3R	42.5	17.6	3.2	1.8	0.7	5.7	1"	1/8"
VTS 20 4R	42.5	17.6	3.2	1.8	0.7	5.7	1"	1/8"
VTS 20 6R	42.5	17.6	5.4	1.9	0.9	8.5	1 1/4"	1/4"
VTS 20 8R	42.5	17.6	7.6	1.9	0.9	9.8	1 1/4"	1/4"



Table 19 Dimensions of hydronic coil exchangers of VTS 30-40 (Fig. 15)

VTS code	LD	HR	C	F	G	TR	OD	Ød
VTS 30 1R	49.3	23.1	2	1.9	1.4	4.3	1 1/4"	1/8"
VTS 30 2R	49.3	23.1	2	1.9	1.4	4.3	1 1/4"	1/8"
VTS 30 3R	49.3	23.1	3.2	1.9	1.4	5.7	1 1/4"	1/8"
VTS 30 4R	49.3	23.1	3.2	1.9	1.4	5.7	1 1/4"	1/8"
VTS 30 6R	49.3	23.1	5.4	2.4	1.7	8.5	2"	1/4"
VTS 30 8R	49.3	23.1	7.6	2.4	1.7	11.2	2"	1/4"
VTS 40 1R	54.8	27.6	2	1.9	0.9	4.3	1 1/4"	1/4"
VTS 40 2R	54.8	27.6	2	1.9	0.9	4.3	1 1/4"	1/4"
VTS 40 3R	54.8	27.6	3.2	1.9	0.9	5.7	1 1/4"	1/4"
VTS 40 4R	54.8	27.6	3.2	1.9	0.9	5.7	1 1/4"	1/4"
VTS 40 6R	54.8	27.6	3.2	2.4	1.2	7.1	2"	1/4"
VTS 40 8R	54.8	27.6	5.4	2.4	1.2	11.2	2"	1/4"

Table 20 Dimensions of hydronic coil exchangers of VTS 55-85 (Fig. 15)

VTS code	LD	HR	C	F	G	TR	OD	Ød
VTS 55 1R	61.9	31.7	2	1.9	1.2	4.3	1 1/4"	1/8"
VTS 55 2R	61.9	31.7	2	1.9	1.2	4.3	1 1/4"	1/8"
VTS 55 3R	61.9	31.7	3.2	2.4	1.6	7.1	2"	1/4"
VTS 55 4R	61.9	31.7	3.2	2.4	1.6	7.1	2"	1/4"
VTS 55 6R	61.9	31.7	5.4	2.4	1.6	8.5	2"	1/4"
VTS 55 8R	61.9	31.7	5.4	3	2.2	11.2	3"	1/2"
VTS 65 1R	70.9	33.0	2	1.9	1.3	4.3	1 1/4"	1/4"
VTS 65 2R	70.9	33.0	2	1.9	1.3	4.3	1 1/4"	1/4"
VTS 65 3R	70.9	33.0	3.2	2.4	1.6	7.1	2"	1/4"
VTS 65 4R	70.9	33.0	3.2	2.4	1.6	7.1	2"	1/4"
VTS 65 6R	70.9	33.0	5.4	2.7	2.2	9.8	3"	1/2"
VTS 65 8R	70.9	33.0	5.4	2.7	2.2	11.2	3"	1/2"
VTS 85 1R	78.6	36.9	2	1.9	1.4	4.3	1 1/4"	1/4"
VTS 85 2R	78.6	36.9	2	1.9	1.4	4.3	1 1/4"	1/4"
VTS 85 3R	78.6	36.9	3.2	2.4	1.7	7.1	2"	1/4"
VTS 85 4R	78.6	36.9	3.2	2.4	1.7	7.1	2"	1/4"
VTS 85 6R	78.6	36.9	5.4	3	2.3	9.8	3"	1/2"
VTS 85 8R	78.6	36.9	5.4	3	2.3	11.2	3"	1/2"

5.5.2 Steam Coils

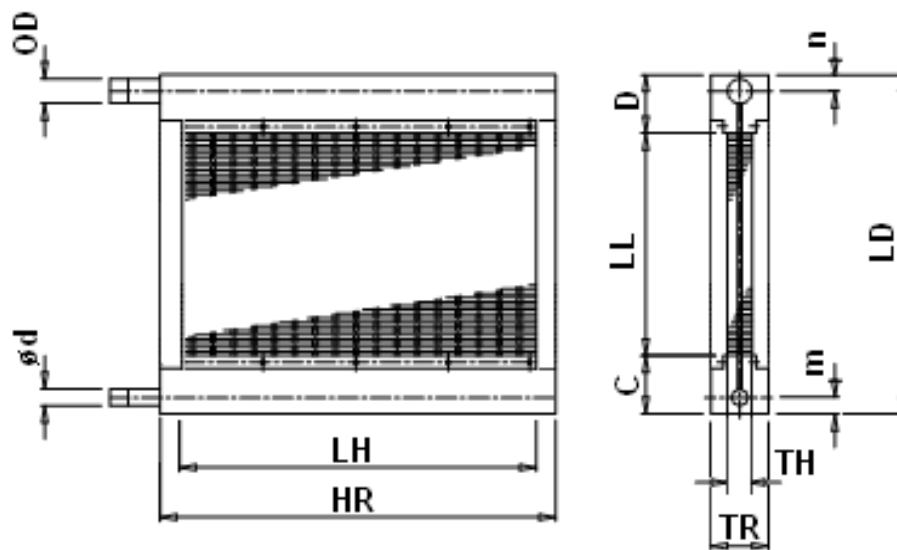

Fig. 16 Dimensions of steam coil exchangers

Table 21 Dimensions of steam coil exchangers (Fig. 16)

AHU Size	VS code	LL	LD	C	D	LH	HR	TH	TR	n	m	OD	Ød
		[in]											
VTS 8	VTS 8 SCL 1	6.0	12.6	2.8	3.9	21.3	23.7	1.1	4.5	1.2	0.6	1"	1/2"
VTS 12	VS 21 SCL 1	6.0	12.6	2.8	3.9	32.5	34.5	1.1	4.5	1.2	0.6	1"	1/2"
VTS 16	VTS 16 SCL 1	7.7	14.6	3.1	3.7	37.5	40.0	1.1	4.5	1.2	0.7	1 1/4"	1"
VTS 20	VS 40 SCL 1	10.2	17.6	3.1	4.3	40.0	42.5	1.1	4.5	1.4	0.7	1 1/2"	1"
VTS 30	VS 55 SCL 1	15.4	23.1	3.3	4.4	46.3	49.3	1.1	4.5	1.4	0.7	2"	1"
VTS 40	VS 75 SCL 1	19.3	27.6	3.3	5	52.5	54.8	1.1	4.5	1.6	0.7	2 1/2"	1"
VTS 50	VS 100 SCL 1	23.0	31.7	3.3	5.4	60.0	61.9	1.1	4.5	1.8	0.7	3"	1"
VTS 65	VS 120 SCL 1	24.2	33.0	3.5	5.3	68.7	70.9	1.1	4.5	1.8	0.9	3"	1 1/4"
VTS 85	VS 150 SCL 1	28.0	36.9	3.6	5.3	76.3	78.6	1.1	4.5	1.8	0.9	3"	1 1/4"

5.5.3 Electric Heaters

The mains supply is to be connected to the electric heater through terminal block that is factory mounted on the back side of unit that is factory mounted on the back side of the unit

Please take the Full Load Amps and Maximum Circuit Breaker from 7.5 section.

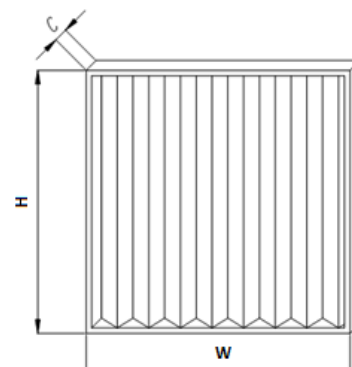

Fig. 17 Layout of electric heater's terminal block.

5.5.4 Air Filters

Plated panel filters in two filtration classes MERV /8/13 and nominal sizes 2" and 4"

AHU	MERV8 (2")		MERV13 (4")	
	WxH [inch]	Qty	WxH [inch]	Qty
VTS 8	24.00 x 14.25	1	24.00 x 14.25	1
VTS 12	34.62 x 14.25	1	34.62 x 14.25	1
VTS 16	40.25 x 16.25	1	40.25 x 16.25	1
VTS 20	42.75 x 19.37	1	42.75 x 19.37	1
VTS 30	16.50 x 24.75	3	16.5 x 24.75	3
VTS 40	18.37 x 29.50	3	18.37 x 29.50	3
VTS 55	20.75 x 33.37	3	20.75 x 33.37	3
VTS 65	23.75 x 34.87	3	23.75 x 34.87	3
VTS 85	19.75 x 38.75	4	19.75 x 38.75	4



6 Installation: Controls

6.1 Installing Wall Mounted Control Box

Wall mounted control box is shipped separately from the air handling unit. The VTS control box is intended for field installation.

Refer to below drawing for dimensions and drilling layout. Place the control box on a solid wall made of noncombustible material (metal plate, concrete wall). Select proper fixing elements, which are suitable for specific wall material and could ensure enough mechanical strength (e.g. plastic anchors for concrete wall).

The surface for assembly should be free of dust and loose particles. The temperature of the wall should be similar to that of surrounding air, in order to avoid water condensation on the wall or on the elements of the control box. Avoid installation on outside walls if not insulated properly. Ensure that air flows freely over the control box to give proper heat dissipation from working electronic equipment. Before beginning installation, follow the wiring

instructions given below. Also, refer to the unit wiring schematic for specific wiring details.

Notes on Installation

Never mount the control box in the area, which is subject to the following conditions:

- Radiant heat from the sun, fireplaces, other appliances, etc.
- Fog, fumes, oil mist or other exhaust from kitchen appliances or industrial processes.
- Dripping water from humidity condensation or any other source.
- Unheated or uncooled spaces behind the controller, such as outside walls or unoccupied spaces.

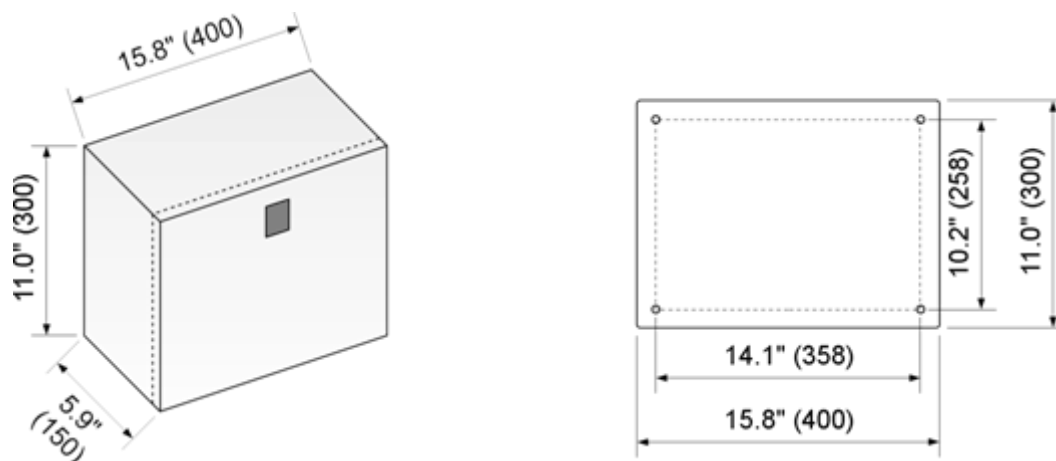

Fig. 18 Dimensions and drilling layout for the control box

6.2 Installing Control Elements

Room temperature sensor

Wall mounted room temperature sensors is shipped in a separate package. Refer to included drawings for sensor dimensions. Position the sensor on an inside wall, three to five feet above the floor and at least two feet from the nearest outside wall. Ensure that air flows freely over the sensor housing. For drilling template use the base of the sensor housing, which can be disassembled by hand. Use spirit level for good aesthetic results. Before beginning installation, follow the wiring instructions given below. Also, refer to the unit wiring schematic for specific wiring details.

Notes on Installation

Avoid mounting the sensor in the area, which is subject to the following conditions:

- Dead spots, such as behind doors or in the corners that do not allow free air circulation.
- Air drafts from stairwells, outside doors, or unsectioned hollow walls.
- Radiant heat from the sun, fireplaces, other appliances, etc.
- Fog, fumes, oil mist or other exhaust from kitchen appliances or industrial processes.
- Dripping water from humidity condensation or any other source.
- Airflow from adjacent zones or other units.
- Unheated or uncooled spaces behind the room sensor, such as outside walls or unoccupied spaces.
- Concealed pipes, air ducts, or chimneys in partition spaces behind the sensor

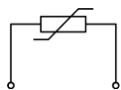

Fig. 19 Electric circuit of the room temperature sensor

Motorized Regulation Valves

Motorized regulation valves are shipped separately from the air handling unit. Refer to below drawings for piping layout and thermal insulation. The valve is supported by surrounding pipes, so ensure proper supports for the pipework to carry the weight of the installation together with the motorized valve. The temperature of surrounding air should be kept low in order to not overheat the actuator. Avoid radiant and convection heat reaching the actuator. Ensure that air flows freely over the actuator to give proper heat dissipation from electronic equipment. Before beginning installation, follow the wiring instructions given below. Also, refer to the unit wiring schematic for specific wiring details.

Notes on Installation

Avoid mounting the motorized regulation valve in the area, which is subject to the following conditions:

- Dead spots, such as the room corners that do not allow free air circulation.
- Under closed covers which do not allow free air circulation.
- Radiant heat from the sun, fireplaces, other appliances, etc.
- Dripping water from humidity condensation or any other source.

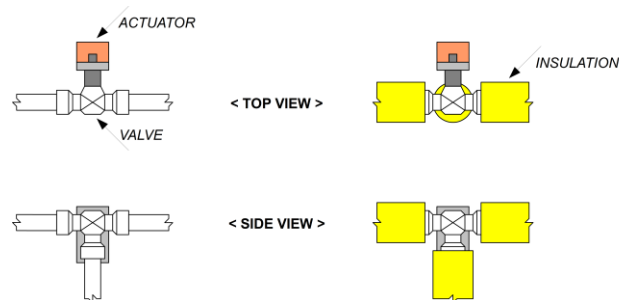

Fig. 20 Recommended pipe insulation

NOTICE! Never insulate the mechanical coupling between the valve body and the actuator!

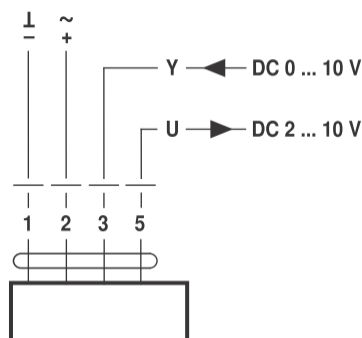

Fig. 21 Connecting the modulating actuator

Air Damper Actuators

Damper actuators are shipped separately from the air handling unit. Refer to below drawings for shape and dimensions. The actuator is supported by the damper's driving spindle and the rotational movement is prevented by dedicated locking lever. Ensure that no excessive mechanical loads occur between the spindle, the actuator and the locking lever. After assembly, run the actuator manually to check for any blockage and too much friction. Ensure that air flows freely over the actuator to give proper heat dissipation from electronic parts. Before beginning installation, follow the wiring instructions given below. Also, refer to

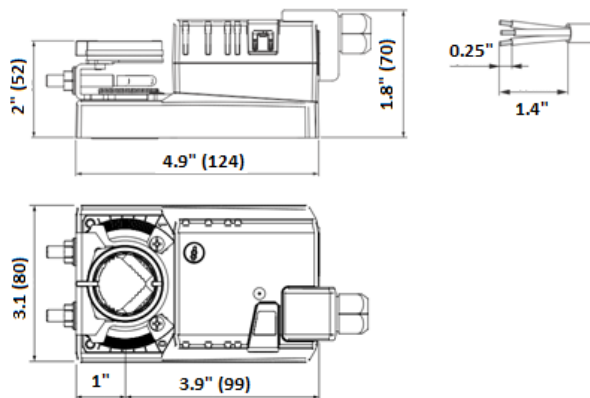

Fig. 22 Dimensions of the standard 10Nm actuator

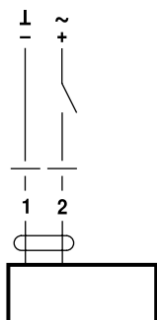

Fig. 23 Connecting the On/Off actuator

the unit wiring schematic for specific wiring details.

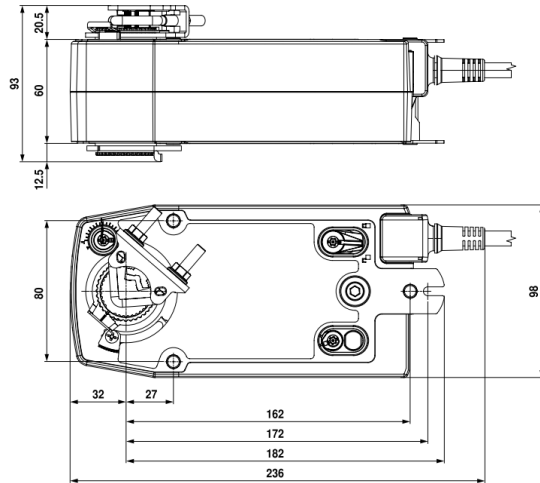

Fig. 24 Dimensions of the spring-return type 10Nm actuator

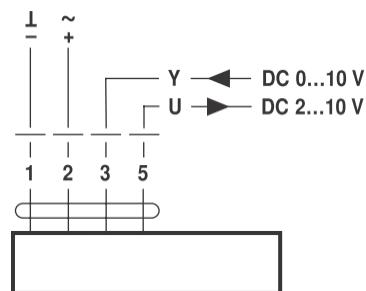

Fig. 25 Connecting the modulating actuator

Notes on Installation

Avoid mounting the motorized regulation valve in the area, which is subject to the following conditions:

- Dead spots, such as the room corners that do not allow free air circulation.
- Under closed covers which do not allow free air circulation.
- Radiant heat from the sun, fireplaces, other appliances, etc.

Anti-Freezing (Anti-Frost)Thermostat

Anti-freezing thermostat is integral part of the heating water coil. It is factory assembled and comes as a standard equipment of the air handling unit. Before beginning installation, follow the wiring instructions given below. Also, refer to the unit wiring schematic for specific wiring details.

Notes on Installation

The anti-freezing thermostat must be considered as important safety device. Not including that element in the control system could cause serious damage to the unit in case

of freezing and breaking the coil. Moreover the building and other property can be seriously affected by flooding from broken coil.

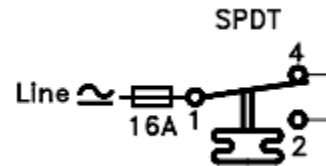

Fig. 26 Connecting the anti-freezing thermostat

Duct Temperature Sensor

Duct temperature sensors are shipped as a separate package. Refer to included drawings for sensor dimensions and drilling layout. Position the sensor in the middle of the duct wall or in the middle the wall of air handling unit (depending on the role in control system). Ensure that air flows freely over the sensor tube. Before beginning installation, follow the wiring instructions given below. Also, refer to the unit wiring schematic for specific wiring details.

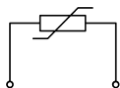

Fig. 27 Electric circuit of the duct temperature sensor

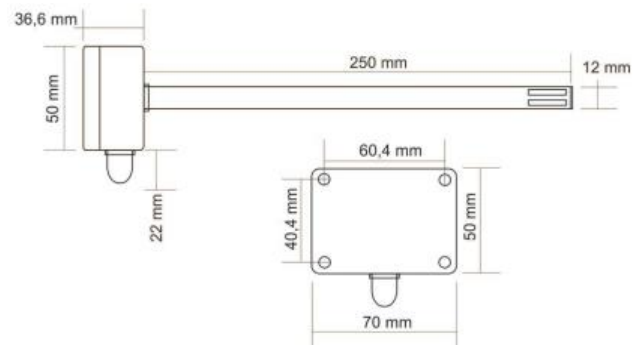

Fig. 28 Dimensions of the duct temperature sensor

Differential Pressure Switch

Differential pressure switches are shipped in a separate package. Refer to included drawings for dimensions and assembly rules. Place the switch on the outside wall of the air handling unit to ensure easy access for adjustment and inspection. Use the connecting tubes and flexible hoses to supply pressure to the switch inputs. Remember not to bend or press the flexible hoses, so the air passes freely to the switch inputs. Note the + and – symbols on the switch inputs and connect the pressure respectively. Before beginning installation, follow the wiring instructions given below. Also, refer to the unit wiring schematic for specific wiring details.

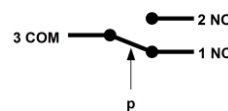

Fig. 29 Electric circuit of the differential pressure switch

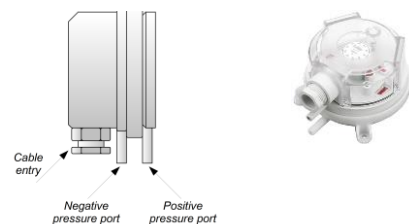

Fig. 30 Connections of the differential pressure switch

HMI Advanced and HMI Basic Interface Installation

Follow the drawings below to install the user interfaces.

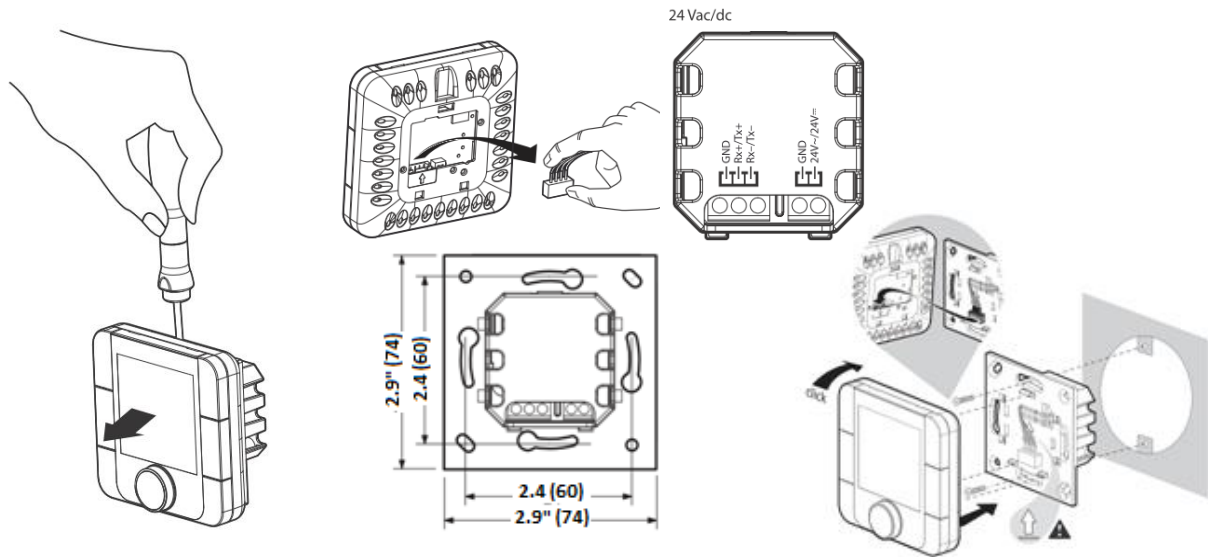

Fig. 31 HMI Basic Interface Installation

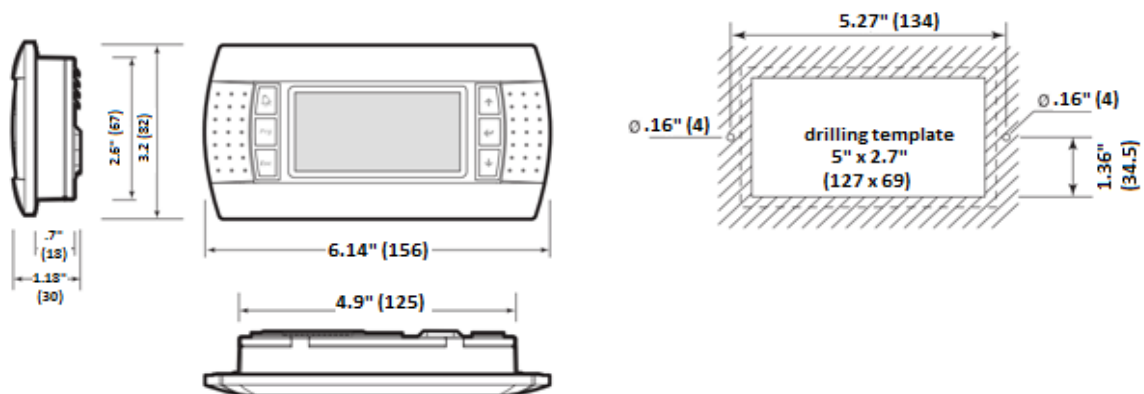

Fig. 32 HMI Advanced - guidelines for panel mounting



Notes on Installation

Avoid mounting interface devices in the area, which is subject to the following conditions:

- Radiant heat from the sun, fireplaces, other appliances, etc.
- Direct sunlight exposure.
- Fog, fumes, oil mist or other exhaust from kitchen appliances or industrial processes.
- Dripping water from humidity condensation or any other source.

Since the HMI Basic could act as a room temperature sensor, observe further remarks on the installation. Avoid mounting the HMI

Basic in the area, which is subject to the following conditions:

- Dead spots, such as behind doors or in the corners that do not allow free air circulation.
- Air drafts from stairwells, outside doors, or unsectioned hollow walls.
- Airflow from adjacent zones or other units.
- Unheated or uncooled spaces behind the room sensor, such as outside walls or unoccupied spaces.
- Concealed pipes, air ducts, or chimneys in partition spaces behind the sensor.

6.3 Installation of Variable Frequency Drive (Frequency Converter)

A variable frequency drive is an integral part of each fan section. It is factory mounted and comes as a standard equipment of the air handling unit. Before beginning installation, follow the wiring instructions given in this document. Especially, refer to the unit wiring schematic for specific wiring details (see the section 7.7 and the section 15.1 in this document).

Notes on Installation

Avoid placing VFD devices in the area, which is subject to the following conditions:

- Radiant heat from the sun, fireplaces, other appliances, etc.
- Direct sunlight exposure.
- Fog, fumes, oil mist or other exhaust from kitchen appliances or industrial processes.
- Dripping water from humidity condensation or any other source.



7 Installation: Electrical

7.1 Unit Wiring Diagrams

Specific unit wiring diagrams are provided on the inside of r. Typical unit wiring diagrams is given below. Use these diagrams for connections or trouble analysis.

⚠ WARNING! *Before starting connecting power supply, check conformity of the voltage and frequency of a supply network with the data shown on the device's rating plate. Permissible fluctuation of the supply voltage and its frequency to the values shown on the rating plate is $\pm 5\%$. If discrepancy exists, the device cannot be connected.*

⚠ WARNING! Hazardous Voltage! *Disconnect all electric power, including remote disconnects before servicing. Follow proper lockout procedures to ensure the power can not be inadvertently energized. Failure to disconnect power before servicing could result in death or serious injury.*

⚠ WARNING! Proper Field Wiring and Grounding Required! *All field wiring MUST be performed by qualified personnel. Improperly installed and grounded field wiring poses FIRE and ELECTROCUTION hazards. To avoid these hazards, you MUST follow requirements for field wiring installation and grounding as described in NEC and your local/state electrical codes. Failure to follow code could result in death or serious injury.*

⚠ WARNING! Correct Phase Critical! *Correct phase sequence is critical. If phase sequence of the incoming line voltage is not correct, it could cause motor damage.*

⚠ WARNING! *Use only copper-core wires!*

7.2 Supply Power Wiring

Ⓞ **Notice:** *Wiring must conform to NEC and all applicable code requirements.*

It is the installer's responsibility to provide adequately-sized power wires and proper unit grounding. Equipment submittals should be referred to for the exact electrical access. Connect the power wires to the power connection point provided (frequency converter's, electric heater's terminal box, control box's terminal).

Connection to the installer-provided ground path must be made to the green wire or green grounding screw provided on each unit. Locate unit wiring diagrams inside device. Refer to the unit-specific wiring diagrams for wiring, connection point, and fuse installation information. Refer to the unit nameplate for unit-specific electrical information, such as voltage, full loads amps. (FLA), maximum circuit breaker (MAX.CKT.BKR).



7.3 Electrical Connections

The mains supply is to be field connected by the installer with:

- **fan's frequency converters** which are factory mounted on the AHU (to energize the fan sets' electric motors).
Power and ground are tucked inside of the frequency converters box
- **electric heater terminal block** that is factory mounted on the AHU (to energize the electric heaters that is embedded inside the AHU).
Power and ground connections are tucked inside the electric heat terminal block.
- **heat wheel's frequency converter** that is factory mounted inside the AHU - to energize the heat wheel's (rotary regenerator's) electric motors.
Power and ground connections are inside the electric heat terminal box,
- **control box that is intended for field mounting** -to energize the control elements and control's system.
Power and ground connections are tucked inside the control box.

Specific unit wiring diagrams are provided on the inside of the control panel door. Typical unit wiring diagrams are in the "Wiring Diagrams". Use these diagrams for connections or trouble analysis

7.4 Electrical Grounding Restrictions

All sensor and input circuits are normally at or near ground (common) potential. When wiring sensors and other input devices to the uPC controller, avoid creating ground loops with grounded conductors external to the unit control circuit. Ground loops can affect the measurement accuracy of the controller.

All input/output circuits (except isolated relay contacts and optically-isolated inputs) assume a grounded source, either a ground wire at the supply transformer to control panel chassis, or an installer supplied ground.

✔ **NOTICE!** Do not connect any sensor or input circuit to an external ground connection.

The installer must provide interconnection wiring to connect wall mounted devices such as a zone sensor module. Refer to the unit

wiring schematic for specific wiring details and point-to-point wiring connections.

Dashed lines indicate field wiring on the unit wiring schematics. All interconnection wiring must conform to NEC Class 2 wiring requirements and any state and local requirements.

✔ **NOTICE!** Do not bundle or run interconnection wiring in parallel with or in the same conduit with any high voltage wires (110V or greater). Exposure of interconnection wiring to high voltage wiring, inductive loads, or RF transmitters may cause radio frequency interference (RFI). In addition, improper separation may cause electrical noise problems. Therefore, use shielded wire (Beldon 83559/83562 or equivalent) in applications that require a high degree of noise immunity. Connect the shield to the chassis ground and tape at the other end.

7.5 Full Load Amps and Maximum Circuit Breaker.

7.5.1 Electric Heater.

Use data that is given below to select relevant wires and to select relevant size of fuses. The data is presented also in the electric heater and AHU's nameplate.

Electric heater: VTS 20 HE 15kW 3~230V		WARNING! / AVERTISSEMENT!	
		Hazardous Voltage! / Voltage dangereux! • Disconnect all electric power, including remote disconnects before servicing. / Avant toute intervention, séparer les sources d'énergie électrique, dispositifs de télécommande inclus. • Follow proper lockout procedures to ensure the power can not be inadvertently energized. Suivre les consignes de condamnation pour prévenir remise sous tension par inadvertance. • Failure to disconnect power before servicing could result in death or serious injury. / Défaut de séparation de l'alimentation électrique avant l'intervention peut entraîner mort ou blessures graves.	
Nominal current	45.7 A	Proper Field Wiring and Grounding Required! / Câblage de champ et mise à terre requise! • All field wiring MUST be performed by qualified personnel improperly installed and grounded field wiring poses FIRE and ELECTROCUTION hazards. / Le câblage de champ DOIT être réalisé par un personnel habilité. Câblage de champ ou mise à terre inapproprié pose le risque de FEU et ELECTROCUTION. • To avoid these hazards, you MUST follow requirements for field wiring installation and grounding as described in NEC and your local/state electrical codes. Pour éviter ces dangers, vous DEVEZ respecter les consignes d'installation de câblage de champ et mise à terre, décrites dans NEC et les consignes électriques locales. • Failure to follow code could result in death or serious injury. Non-respect de ces consignes peut entraîner mort ou blessures graves.	
Single heating element	13.2 A	Correct Phase Critical! Hot temperature! Câblage de phase correct critique! Température haute!	
Nominal power	20.12 HP		
Single heating element	4.02 HP		
Max. CKT. BKR	60.0 A		
Single heating element	20.0 A		
Min air flow	743 CFM		
Max air flow	2230 CFM		
Max Outlet Temp	104 °F		
Production place	USA		
Production date	3/31/2014		
VTS America Inc. 1650 Horizon Parkway NE, Suite 100, Buford, GA 30518, USA			

Fig. 33 A template of a nameplate of the electric heater

Table 22 Electric Heaters 1/208 [V] and 1/30 [V] (60 Hz)

Heat. elements	1x208 [V]			1x230 [V]		
	FLA	Pn	MAX. CKT.BKR.	FLA	Pn	MAX. CKT.BKR.
▼	[A]	[kW]	[A]	[A]	[kW]	[A]
1	11.9	2.5	15	13.2	3	20
2	23.8	5.0	30	26.4	6	35
3	35.7	7.4	45	39.6	9	50
4	47.6	9.9	60	52.8	12	70
5	59.5	12.4	70	66.0	15	80
6	71.4	14.9	90	79.2	18	90
7	83.3	17.4	100	92.4	21	110
8	95.2	19.8	110	105.6	24	125
9	107.1	22.3	125	-	-	-
10	119.0	24.8	150	-	-	-

Table 23 Electric Heaters 3/208 [V] and 3/230 [V] (60Hz)

Heat. elements	3x208 [V]			3x230 [V]		
	FLA	Pn	MAX. CKT.B KR.	FLA	Pn	MAX. CKT.B KR.
▼	[A]	[kW]	[A]	[A]	[kW]	[A]
1	11.9	2.5	15	13.2	3	20
2	20.6	5.0	25	22.8	6	30
3	20.6	7.4	25	22.8	9	30
4	30.7	9.9	40	34.0	12	40
5	41.3	12.4	50	45.7	15	60
6	41.3	14.9	50	45.7	18	60
7	51.9	17.4	60	57.4	21	70
8	61.9	19.8	80	68.5	24	80
9	61.9	22.3	80	68.5	27	80
10	72.3	24.8	90	80.0	30	100
11	82.6	27.3	100	91.3	33	110
12	82.6	29.8	100	91.3	36	110
13	93.1	32.2	110	103.0	39	125
14	103.1	34.7	125	114.0	42	150
15	103.1	37.2	125	114.0	45	150
16	113.9	39.7	150	126.0	48	150
17	123.9	42.2	150	13.2	3	20
18	123.9	44.6	150	22.8	6	30



Table 24 Table 21 Electric Heaters 3x460 [V] (60Hz)

Heat. elements ▼	FLA	Pn	MAX.CKT.BKR.	Heat. elements ▼	FLA	Pn	MAX.CKT.BKR.
	[A]	[kW]	[A]		[A]	[kW]	[A]
1	6.6	3	10	15	57.0	45	70
2	11.4	6	15	16	63.0	48	80
3	11.4	9	15	17	68.5	51	80
4	17.0	12	20	18	68.5	54	80
5	22.9	15	30	19	74.0	57	90
6	22.9	18	30	20	80.0	60	100
7	28.7	21	35	21	80.0	63	100
8	34.3	24	40	22	85.5	66	100
9	34.3	27	40	23	91.5	69	110
10	40.0	30	50	24	91.5	72	110
11	45.7	33	60	25	97.0	75	110
12	45.7	36	60	26	102.5	78	125
13	51.5	39	60	27	102.5	81	125
14	57.0	42	70				

7.5.2 Electric motor with frequency converter.

Use data that is given below to select relevant wires and to select relevant size of fuses. The data is presented also in the electric heater and AHU's nameplate.

Table 25 Full Load Amps and Maximum Circuit Breaker (1x208V)

Motor		FC Input			MAX.CKT. BKR	FC Output (el. motor input)	
Type	Casing	FLA	Phase	Un		Phase	Uo
		A		V	A	V	
EL.MTR 56-0.75HP/2p	OPSB	2.8	1	208	6	3	208
EL.MTR 56-1HP/2p	OPSB	3.0	1	208	10	3	208
EL.MTR 145T-2HP/2p	OPSB	5.6	1	208	15	3	208
EL.MTR 143T-1HP/4p	OPSB	3.1	1	208	10	3	208
EL.MTR 145T-1.5HP/4p	OPSB	4.5	1	208	10	3	208
EL.MTR 145T-2HP/4p	OPSB	5.8	1	208	15	3	208
EL.MTR 182T-3HP/4p	OPSB	8.5	1	208	20	3	208
EL.MTR 56-0.75HP/2p	TEFC	2.5	1	208	6	3	208
EL.MTR 56-1HP/2p	TEFC	2.9	1	208	6	3	208
EL.MTR 145T-2HP/2p	TEFC	5.5	1	208	15	3	208
EL.MTR 143T-1HP/4p	TEFC	3.3	1	208	10	3	208
EL.MTR 145T-1.5HP/4p	TEFC	4.5	1	208	10	3	208
EL.MTR 145T-2HP/4p	TEFC	6.0	1	208	15	3	208
EL.MTR 182T-3HP/4p	TEFC	8.4	1	208	20	3	208



Table 26 Full Load Amps and Maximum Circuit Breaker (1x230V)

Motor			FC Input		MAX.CKT. BKR	FC Output (el. motor input)	
Type	Casing	FLA	Phase	Un		Phase	Uo
		A		V			
EL.MTR 56-0.75HP/2p	OPSB	2.52	1	230	6	3	230
EL.MTR 56-1HP/2p	OPSB	2.9	1	230	6	3	230
EL.MTR 145T-2HP/2p	OPSB	5.0	1	230	15	3	230
EL.MTR 143T-1HP/4p	OPSB	3.0	1	230	10	3	230
EL.MTR 145T-1.5HP/4p	OPSB	4.4	1	230	10	3	230
EL.MTR 145T-2HP/4p	OPSB	5.8	1	230	15	3	230
EL.MTR 182T-3HP/4p	OPSB	7.7	1	230	20	3	230
EL.MTR 56-0.75HP/2p	TEFC	2.26	1	230	6	3	230
EL.MTR 56-1HP/2p	TEFC	2.8	1	230	6	3	230
EL.MTR 145T-2HP/2p	TEFC	4.9	1	230	15	3	230
EL.MTR 143T-1HP/4p	TEFC	2.9	1	230	6	3	230
EL.MTR 145T-1.5HP/4p	TEFC	4.0	1	230	10	3	230
EL.MTR 145T-2HP/4p	TEFC	5.4	1	230	15	3	230
EL.MTR 182T-3HP/4p	TEFC	7.6	1	230	20	3	230

Table 27 Full Load Amps and Maximum Circuit Breaker (3x208V)

Motor			FC Input		MAX.CKT. BKR	FC Output (el. motor input)	
Type	Casing	FLA	Phase	Un		Phase	Uo
		A		V			
EL.MTR 56-0.75HP/2p	OPSB	2.79	3	208	6	3	208
EL.MTR 56-1HP/2p	OPSB	3.0	3	208	6	3	208
EL.MTR 145T-2HP/2p	OPSB	5.6	3	208	10	3	208
EL.MTR 143T-1HP/4p	OPSB	3.1	3	208	6	3	208
EL.MTR 145T-1.5HP/4p	OPSB	4.5	3	208	6	3	208
EL.MTR 145T-2HP/4p	OPSB	5.8	3	208	10	3	208
EL.MTR 182T-3HP/4p	OPSB	8.5	3	208	15	3	208
EL.MTR 184T-5HP/4p	OPSB	14.0	3	208	20	3	208
EL.MTR 213T-7.5HP/4p	OPSB	20.5	3	208	25	3	208
EL.MTR 215T-10HP/4p	OPSB	27.4	3	208	35	3	208
EL.MTR 56-0.75HP/2p	TEFC	2.5	3	208	3	3	208
EL.MTR 56-1HP/2p	TEFC	2.9	3	208	6	3	208
EL.MTR 145T-2HP/2p	TEFC	5.5	3	208	10	3	208
EL.MTR 143T-1HP/4p	TEFC	3.3	3	208	6	3	208
EL.MTR 145T-1.5HP/4p	TEFC	4.5	3	208	6	3	208
EL.MTR 145T-2HP/4p	TEFC	6.0	3	208	10	3	208
EL.MTR 182T-3HP/4p	TEFC	8.4	3	208	10	3	208
EL.MTR 184T-5HP/4p	TEFC	14.4	3	208	20	3	208
EL.MTR 213T-7.5HP/4p	TEFC	20.0	3	208	25	3	208
EL.MTR 215T-10HP/4p	TEFC	27.0	3	208	35	3	208



Table 28 Full Load Amps and Maximum Circuit Breaker (3x230V)

Motor			FC Input		MAX.CKT. BKR	FC Output (el. motor input)	
Type	Casing	FLA	Phase	Un		Phase	Uo
		A		V			A
EL.MTR 56-0.75HP/2p	OPSB	2.52	3	230	6	3	230
EL.MTR 56-1HP/2p	OPSB	2.9	3	230	6	3	230
EL.MTR 145T-2HP/2p	OPSB	5.0	3	230	6	3	230
EL.MTR 143T-1HP/4p	OPSB	3.0	3	230	6	3	230
EL.MTR 145T-1.5HP/4p	OPSB	4.4	3	230	6	3	230
EL.MTR 145T-2HP/4p	OPSB	5.8	3	230	10	3	230
EL.MTR 182T-3HP/4p	OPSB	7.7	3	230	10	3	230
EL.MTR 184T-5HP/4p	OPSB	12.7	3	230	15	3	230
EL.MTR 213T-7.5HP/4p	OPSB	18.5	3	230	25	3	230
EL.MTR 215T-10HP/4p	OPSB	24.8	3	230	30	3	230
EL.MTR 56-0.75HP/2p	TEFC	2.26	3	230	3	3	230
EL.MTR 56-1HP/2p	TEFC	2.8	3	230	6	3	230
EL.MTR 145T-2HP/2p	TEFC	4.9	3	230	6	3	230
EL.MTR 143T-1HP/4p	TEFC	2.9	3	230	6	3	230
EL.MTR 145T-1.5HP/4p	TEFC	4.0	3	230	6	3	230
EL.MTR 145T-2HP/4p	TEFC	5.4	3	230	10	3	230
EL.MTR 182T-3HP/4p	TEFC	7.6	3	230	10	3	230
EL.MTR 184T-5HP/4p	TEFC	13.0	3	230	20	3	230
EL.MTR 213T-7.5HP/4p	TEFC	18.1	3	230	25	3	230
EL.MTR 215T-10HP/4p	TEFC	24.4	3	230	30	3	230

Table 29 Full Load Amps and Maximum Circuit Breaker (3x460V)

Motor			FC Input		MAX.CKT. BKR	FC Output (el. motor input)	
Type	Casing	FLA	Phase	Un		Phase	Uo
		A		V			A
EL.MTR 56-0.75HP/2p	OPSB	1.26	3	460	3	3	460
EL.MTR 56-1HP/2p	OPSB	1.45	3	460	3	3	460
EL.MTR 145T-2HP/2p	OPSB	2.5	3	460	3	3	460
EL.MTR 143T-1HP/4p	OPSB	1.5	3	460	3	3	460
EL.MTR 145T-1.5HP/4p	OPSB	2.2	3	460	3	3	460
EL.MTR 145T-2HP/4p	OPSB	2.9	3	460	6	3	460
EL.MTR 182T-3HP/4p	OPSB	3.9	3	460	6	3	460
EL.MTR 184T-5HP/4p	OPSB	6.3	3	460	10	3	460
EL.MTR 213T-7.5HP/4p	OPSB	9.25	3	460	15	3	460
EL.MTR 215T-10HP/4p	OPSB	12.4	3	460	15	3	460
EL.MTR 56-0.75HP/2p	TEFC	1.1	3	460	3	3	460
EL.MTR 56-1HP/2p	TEFC	1.4	3	460	3	3	460
EL.MTR 145T-2HP/2p	TEFC	2.5	3	460	3	3	460
EL.MTR 143T-1HP/4p	TEFC	1.5	3	460	3	3	460
EL.MTR 145T-1.5HP/4p	TEFC	2.0	3	460	3	3	460
EL.MTR 145T-2HP/4p	TEFC	2.7	3	460	6	3	460
EL.MTR 182T-3HP/4p	TEFC	3.8	3	460	6	3	460
EL.MTR 184T-5HP/4p	TEFC	6.5	3	460	10	3	460
EL.MTR 213T-7.5HP/4p	TEFC	9.1	3	460	15	3	460
EL.MTR 215T-10HP/4p	TEFC	12.2	3	460	15	3	460



7.6 Controller Wiring

Units with CAREL μ PC (UPC in VTS coding)

Control boxes for air handling units Ventus, rely on specialized HVACR compact controller type μ PC from CAREL INDUSTRIES. The hardware resources of the controller include:

- Digital inputs
- Digital outputs (relays)
- Analog inputs of various types (voltage, resistance)
- Analog outputs (0-10V)
- Communication port for proprietary protocol for HMI Advanced
- Communication port RS485 for local Modbus communication (within single unit)
- Extension port for BMS communication card

As a sophisticated electronic device for industrial environment, the controller requires specific installation rules regarding cable works. That includes use of certain types of cables, which are matching characteristics of the hardware, and also proper cable placement and work out method.

HMI Advanced delivery includes dedicated flat cable with RJ11 plugs for fast and easy peer to peer connection. Use that cable at close distances from the control box (e.g. for service purposes).

Note, that the cable supports both transmission and power to the device. For more distant connections use the UTP cable instead. As an RS485 connection, that link can operate up to

3900 feet distance. However, observe the need for termination at distances bigger than 400 feet and check the polarity of the wires at distanced exceeding 1000 feet.

Local Modbus communication uses daisy chain topology with maximum of 5 devices on the bus. The controller is the Master. The HMI Basic, the VFD for supply fan, the VFD for exhaust fan and the VFD for rotary heat regeneration are Slaves. The whole bus is limited to 3900 feet length as measured between the most distant devices. However, observe the need for termination at distances bigger than 400 feet and check the polarity of the wires at distances exceeding 1000 feet.

Follow these general guidelines when installing communication wiring on units:

- Install all communication wiring in accordance with the NEC and all local codes.
- Solder the conductors and insulate (tape) the joint sufficiently when splicing communication wire. Do not use wire nuts to make the splice.
- Do not pass communication wiring between buildings because the unit will assume different ground potentials.
- Do not run power in the same conduit or wire bundle with communication link wiring.

✔ NOTICE!

1. Control box CBX.UPC must be powered from the main switchgear equipped with appropriate protection of wires powering the control box.
2. Assembly, wiring and start-up of the control gear should be done by qualified staff only.
3. For applications subject to strong vibrations (.6 mm pk-pk 10/55 Hz), secure the cables connected to the μ PC using clamps placed around .12" from the connectors.

4. The entire length of the input/output connections must be less than 98.4 ft.
5. Installation must be performed according to the standards and legislation in force in the country where the appliance is used.
6. In the event of malfunctions do not attempt to repair the controller, but rather contact the service.
7. Control box can work inside a building only. Assembly outside is forbidden.

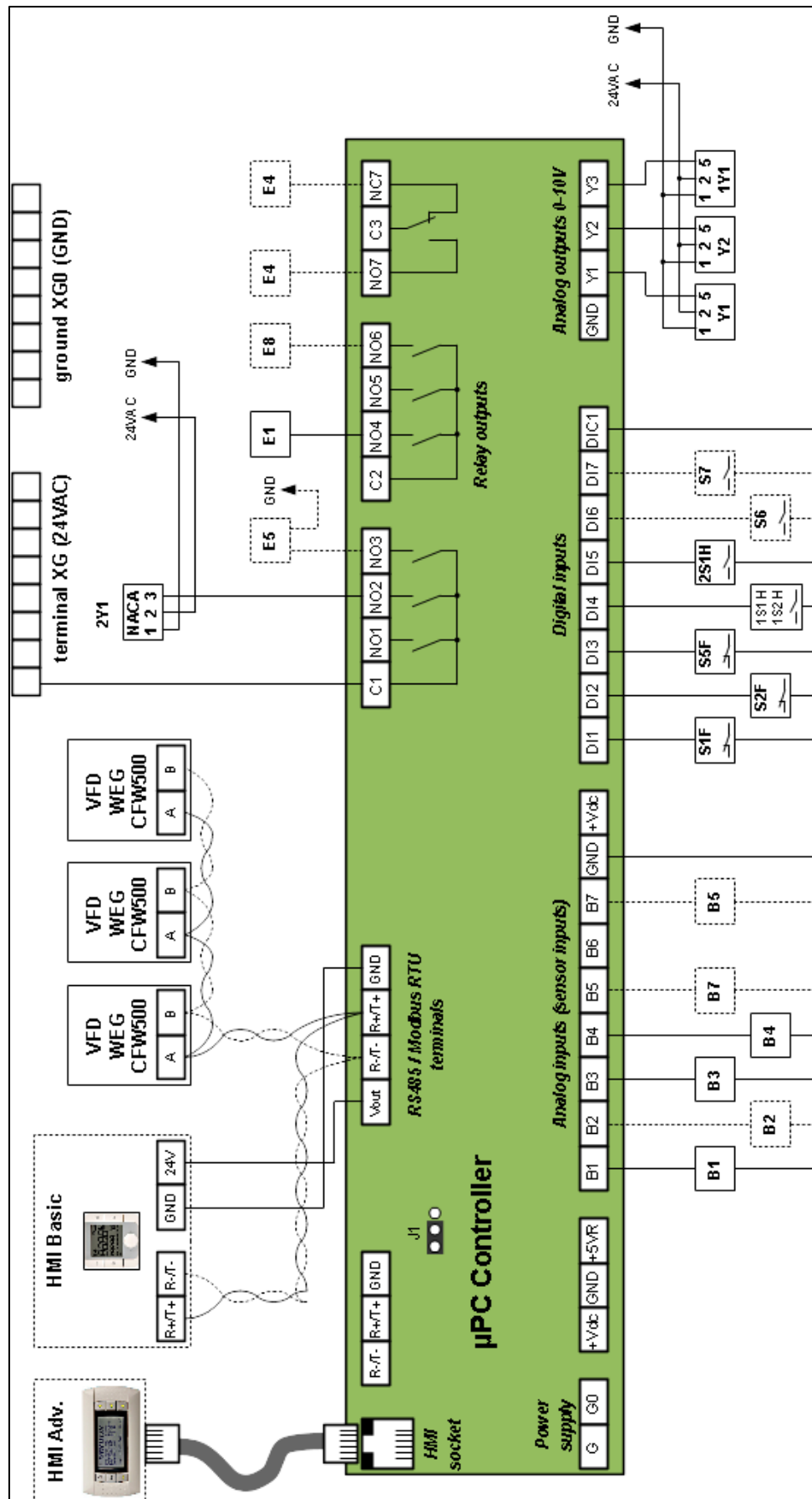

Fig. 34 Controller Wiring - general layout

7.7 Frequency Converter Wiring

The power and grounding connections are shown in the section 8.1 **Connection the mains supply with frequency converters.**

✔ **WARNING !** Provide a disconnect device for the inverter power supply. This device must cut off the power supply whenever necessary (during maintenance for instance).

✔ **CAUTION!** The input power supply voltage must be compatible with the inverter rated voltage. Power factor correction capacitors are not needed at the inverter input (L/L1, N/L2, L3 or R, S, T) and must not be installed at the output (U, V, W).

✔ **NOTICE !** The power supply that feeds the inverter must have a grounded neutral.

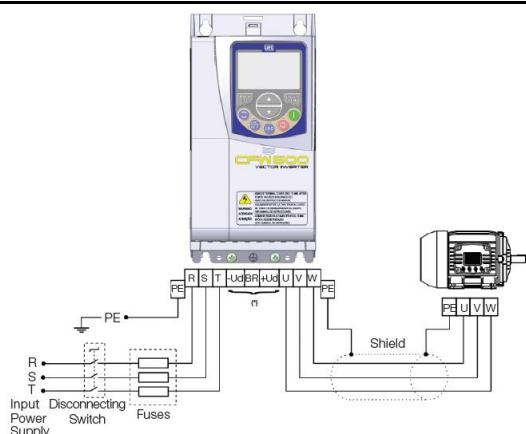

Fig. 35 Power and grounding connections

In case of IT networks, follow the instructions: In a general way, the applied inverters can be installed directly in the power supply, without reactance in the supply. However, check the following:

- In order to prevent damages to the inverter and assure the expected useful life, you must have a minimum impedance that provide a voltage drop of the input power supply of 1 %. If the impedance of the input power supply (due to the transformers and cabling) is below the values listed in this table, we recommend

the use of reactance in the input power supply.

- For the calculation of the input power supply reactance necessary to obtain the desired percentage voltage drop, use:

$$L = 1592 \cdot \Delta V \cdot \frac{V_e}{I_{s, rat} \cdot f} [\mu H]$$

seeing that:

ΔV - desired input power supply drop, in percentage (%).

V_e - voltage of the phase in inverter input, in volts (V).

$I_{s, rat}$ - inverter output rated current.

f - input power supply frequency.

The control connection.

The control connections (analog input/output, digital input/output and interface RS485) must be performed according to the specification of the connector of the plug-in module connected to the frequency converter. The typical functions and connections for the standard plug-in module are shown below.

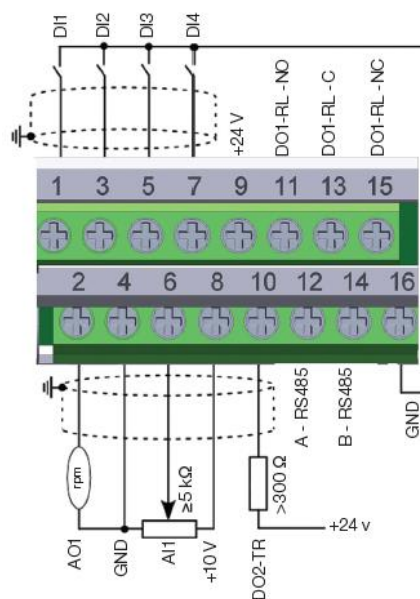

Fig. 36 Signals of the connector of the plug-in module

Table 30 Signals of the connector of the FC plug-in module (Fig. 38)

Top Connection	1	DI1	Digital input 1
	3	DI2	Digital input 2
	5	DI3	Digital input 3
	7	DI4	Digital input 4
	9	+24V	Power supply+24 Vdc
	11	DO1-RL-NO	Digital output 1 (NA Contact of Relay 1)
	13	DO1-RL-C	Digital output 1 (Common point of Relay 1)
	15	DO1-RL-NC	Digital output 1 (NF Contact of Relay 1)

Table 31 (cont.) Signals of the connector of the FC plug-in module (Fig. 38)

Bottom Connection	2	AO1	Analog output 1
	4	GND	Reference 0 V
	6	AI1	Analog input 1
	8	+10V	Reference +10 Vdc for potentiometer
	10	DO2-TR	Digital output 2 (Transistor)
	12	RS485 - A	RS485 (terminal A)
	14	RS485 -A	RS485 (terminal B)
	16	GND	Reference 0 V

Table 32 Frequency converter electronics - general data

CONTROL	METHOD	Type of control: <ul style="list-style-type: none"> • V/f (Scalar); • VVW: Voltage vector control. • PWM SVM (Space Vector Modulation)
PERFORMANCE	OUTPUT FREQUENCY	0 to 500 Hz, resolution of 0.015 Hz.
	VECTOR CONTROL (VVW)	<ul style="list-style-type: none"> • Speed regulation: 1 % of the rated speed (with slip compensation). • Speed variation range: 1:20.
INPUTS	ANALOG	1 insulated input. Levels: (0 to 10) V or (0 a 20) mA or (4 to 20) mA. <ul style="list-style-type: none"> • Linearity error = 0.25 %. • Impedance: 100 kO for voltage input, 500 O for current input. • Programmable functions. • Maximum voltage permitted in the input: 30 Vdc.
	DIGITAL	<ul style="list-style-type: none"> • 4 insulated inputs. • Programmable functions: <ul style="list-style-type: none"> ○ active high (PNP): maximum low level of 15 Vdc. ○ minimum high level of 20 Vdc. ○ active low (NPN): maximum low level of 5 Vdc. ○ minimum high level of 9 Vdc. • Maximum input voltage of 30 Vdc. • Input current: 4.5 mA. • Maximum input current: 5.5 mA.

8 Installation: Mechanical

8.1 Installing the Unit

Install vertical units on the floor. The floor mounted AHUs are factory fitted with supportive block in sizes H x W x L = 3.1" x 7.9" x 7.9" each.

A supportive blocks' layout is given below (Fig. 40 and Fig 41).

Table 33 The W1 dimension for Fig. 40 and Fig. 41

AHU size	W1 [in]
8	29.25
12	39.92
16	45.51
20	48.07
30	54.80
40	60.35
55	67.44
65	76.54
85	84.17

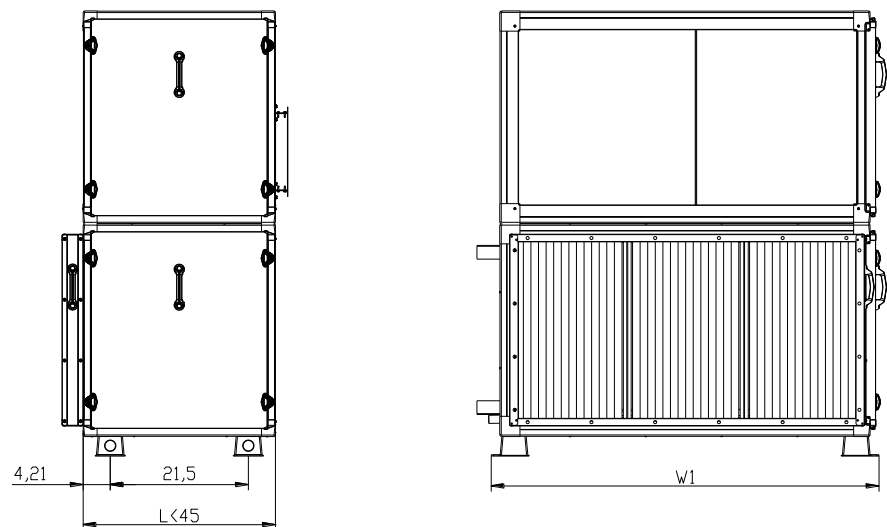

Fig. 37 The location of supportive elements of VTS 8-85 AHUs, which length is less than 30 inches.

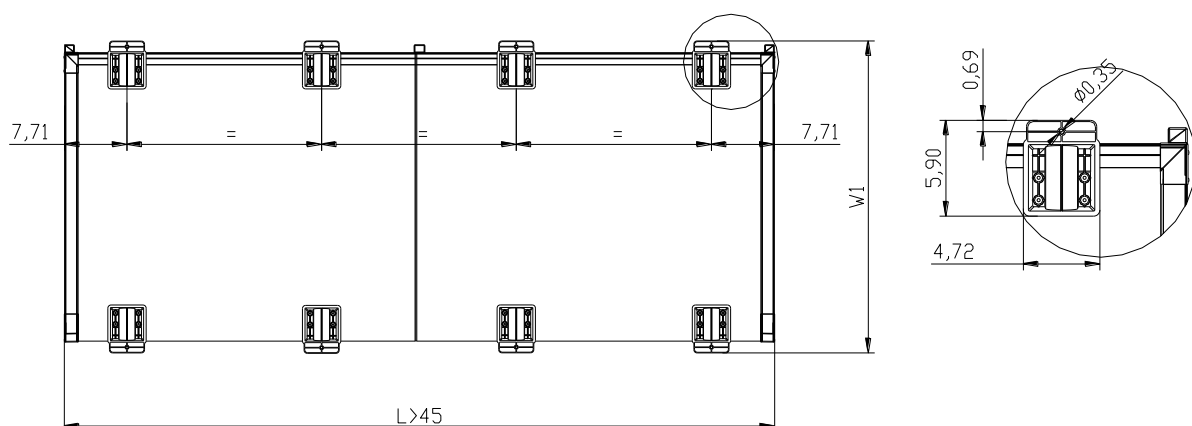

Fig. 38 The location of supportive (blocks) elements of VTS 8-85 AHUs, which length is more than 30 inches. W1 dimension is given in the table 36.

Hanging of the units

The horizontal AHUs can be suspended. Assembly of the AHU as a suspended device, in a line of ventilation ducts is to be carried out by the qualified personnel only, with the use of standard elements (not delivered) used for suspending ventilation ducts (threaded rods and steel/aluminum bars or channels).

Allow:

- adequate service clearances as recommended in this document.
- adequate service clearances for P-trap

✓ **WARNING!** *Be sure that used elements are able to carry the weight equal to 150% of AHU weight that is given in device nameplate.*

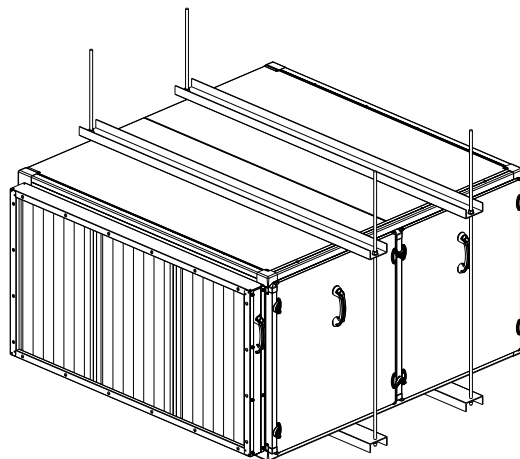

Fig. 39 Example of suspending the AHU with external rigging

8.2 Condensate Drain Connections

✓ **NOTICE!** *It is the installer's responsibility to provide adequate condensate piping to prevent potential water damage to the equipment and/or building.*

Size the main drain lines and trap them the same size as the drain connection, which is 1 1/4".

The outlet condensate connections, led outside the AHU's casing are embedded in the drain plates underneath a glycol, cross-flow and rotary exchangers (the diameter of drain pan connection pipe is 1 1/4").

Drain traps, which are designed to drain out condensed water from the exchangers at the different pressure inside the AHU and environment, should be connected to the drain system.

All drain lines downstream of the trap must flow continuously downhill. If segments of the line are routed uphill, this can cause the drain line to become pressurized. A pressurized drain line may cause the trap to back up into the drain pan, causing overflow.

✓ **NOTICE!** *The manufacturer does not deliver drainage traps.*

For proper drainage of condensate from the unit, the P-trap on the drain pan connection pipe must be installed where the negative pressure occurs.

Plug or trap the auxiliary connection to prevent air from being drawn in and causing carryover fig. 43 and table 37.

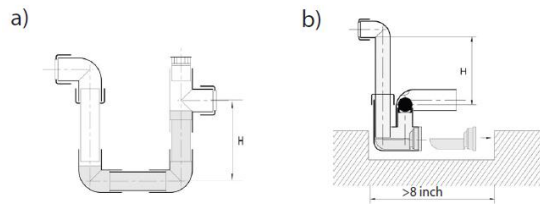

Fig. 40 Drain trap's type

Table 34 Drain trap's operational height

No.	Total fan's pressure [in w.g.]	Size H [in]
1.	<2,42	2,36
2.	2,42-4,03	3,94
3.	4,03-5,65	5,51
4.	5,65-7,26	7,09
5.	7,26-8,87	8,66

The "H" of the drain trap depends on the pressure difference between the AHU section, where condensate is drained from during operation and the ambient pressure. „H" dimension is provided in inches and must be

higher than the pressure difference expressed in w.g..

✔ **NOTICE!** *Due to various pressure difference values which can be presented in various AHU sections during operation it is not allowable to connect several condensate outlets into one P-trap.*

It is possible to join together drain traps of various sections with one drain interceptor provided that the interceptor will be equipped with air-escape. Before starting the AHU, fill the siphon with water. In case of cold environment, insulate the water drain system and eventually apply suitable heating system.

✔ **NOTICE!** *Potential Coil-Freeze Condition!*
Make provisions to drain the coil when not in use to prevent coil freeze-up. Failure to follow this procedure could result in equipment/property damage.

8.3 Duct Connections

Before any service please make sure that any of AHU elements are not energized.

⚠ WARNING: Hazardous Voltage! Disconnect all electric power, including remote disconnects before servicing. Follow proper lockout/tagout procedures to ensure the power cannot be inadvertently energized. Failure to disconnect power before servicing could result in death or serious injury.

Install all air ducts according to the National Fire Protection Association standards for the "Installation of Air Conditioning and Ventilation Systems other than Residence Type (NFPA 90A) and Residence Type Warm Air Heating and Air Conditioning Systems (NFPA 90B).

The ducts connected to the AHU have to be suspended or underpinned with dedicated support elements. Conducting the ducts with the fittings should be done in a way to eliminate possible increase of noise level in the ventilation system.

Make duct connections to the unit with a flexible material such as heavy canvas to help minimize noise and vibration. Use three inches for the return duct and three inches for the discharge duct. Keep the material loose to absorb fan vibration.

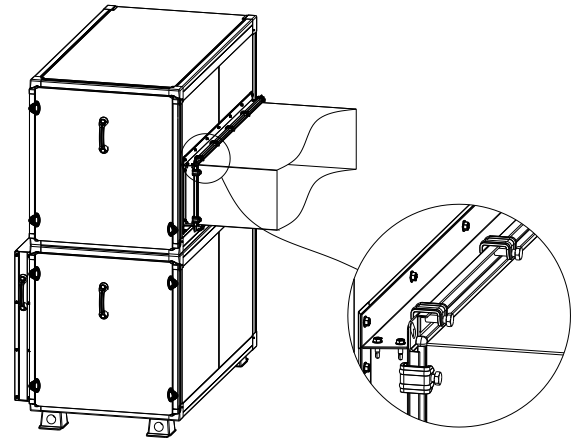

Fig. 41 Example of duct's connection

To achieve maximum acoustical performance, minimize the duct static pressure setpoint.

9 Installation: Piping

9.1 Hydronic Coil Connections

The water coils (hot water coils and chilled water coils) are fitted with threaded manifolds. Proper installation and piping is necessary to ensure satisfactory coil operation and prevent operational damage. Water inlet and outlet connections extend through the coil section side panel (see Figure 25). Follow standard piping practices when piping to the coil.

Connection of the coil exchangers should be carried out in such a way to prevent it from stresses which may result in mechanical damage or leakage. The pipeline weight and thermal stresses cannot be passed onto the exchanger's connections. Depending on local conditions please use the compensation at the supply and return of the pipeline system, in order to level the pipeline's linear expansion.



Fig. 42 Unit coil connection layout

When connecting assembly of the supply system to the exchangers equipped with the

threaded connections, counter the exchanger's connection with additional wrench (Fig.46).

The supply system should be planned in such a way that it doesn't get in the way of any maintenance work. Applied method of connecting the exchangers with the supply system should allow for an easy pipeline disassemble in order to remove the exchanger from the AHU, during service operations.

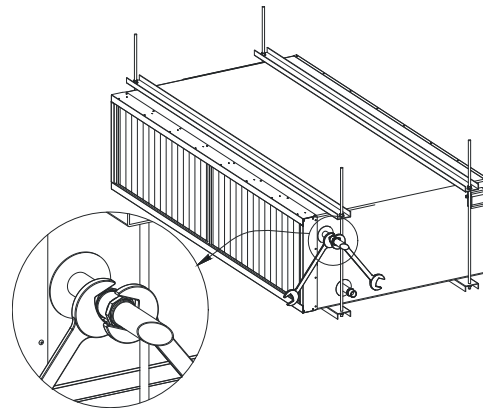

Fig. 43 Securing the threaded connections of the exchanger

The symbol of water coil (hot water and chilled water) consists of:

- AHU size - VTS **XX** and
- number of rows WCL **Y**.

Table 35 The hydronic coil exchangers' volume

Coils code	Volume	Coils code	Volume	Coils code	Volume
	[CI]		[CI]		[CI]
VTS 8 WCL 1	46	VTS 20 WCL 1	134	VTS 55 WCL 1	347
VTS 8 WCL 2	90	VTS 20 WCL 2	199	VTS 55 WCL 2	522
VTS 8 WCL 3	136	VTS 20 WCL 3	289	VTS 55 WCL 3	681
VTS 8 WCL 4	167	VTS 20 WCL 4	395	VTS 55 WCL 4	1 042
VTS 8 WCL 6	245	VTS 20 WCL 6	594	VTS 55 WCL 6	1 564
VTS 8 WCL 8	322	VTS 20 WCL 8	792	VTS 55 WCL 8	2 084
VTS 12 WCL 1	79	VTS 30 WCL 1	201	VTS 65 WCL 1	407
VTS 12 WCL 2	109	VTS 30 WCL 2	291	VTS 65 WCL 2	633
VTS 12 WCL 3	134	VTS 30 WCL 3	409	VTS 65 WCL 3	718
VTS 12 WCL 4	217	VTS 30 WCL 4	575	VTS 65 WCL 4	1 266
VTS 12 WCL 6	323	VTS 30 WCL 6	864	VTS 65 WCL 6	1 899
VTS 12 WCL 8	432	VTS 30 WCL 8	1 150	VTS 65 WCL 8	2 532
VTS 16 WCL 1	92	VTS 40 WCL 1	252	VTS 85 WCL 1	538
VTS 16 WCL 2	178	VTS 40 WCL 2	400	VTS 85 WCL 2	785
VTS 16 WCL 3	254	VTS 40 WCL 3	427	VTS 85 WCL 3	1 005
VTS 16 WCL 4	335	VTS 40 WCL 4	797	VTS 85 WCL 4	1 571
VTS 16 WCL 6	490	VTS 40 WCL 6	1 194	VTS 85 WCL 6	2 356
VTS 16 WCL 8	647	VTS 40 WCL 8	1 594	VTS 85 WCL 8	3 142

⚠ CAUTION! *The maximum operation pressure is 246 PSI (17 bar). Testing pressure 493 PSI (34 bar). The maximum temperature is 200°F.*

Supply and return exchanger connections should be connected so as the exchanger operates in a counter flow way. A parallel flow of air and medium could result in lower mean temperature difference, thus in the lower exchanger's performance.

✔ NOTICE: *Potential Coil-Freeze Condition! Secure the coil against freezing-up! Failure to follow this procedure could result in equipment/property damage.*

Some examples of connecting of supply and return pipelines for various AHU versions are shown in the picture below.

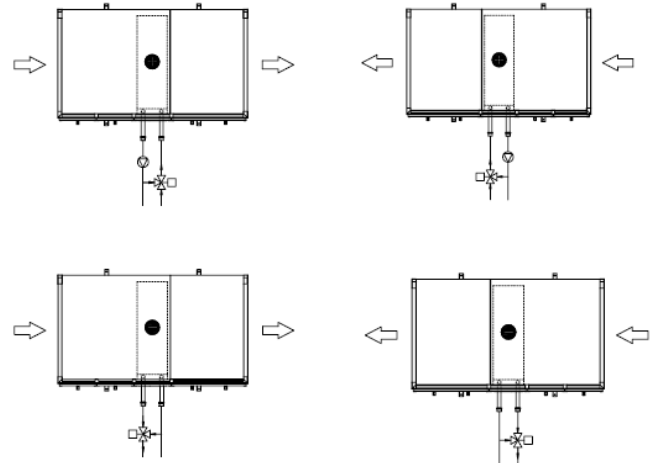

Fig. 44 Examples of feeding water exchangers (top view)

9.2 Steam Piping

Proper installation, piping and trapping is necessary to insure satisfactory and trouble-free operation of a steam heating coil.

The steam coils are fitted with threaded manifolds.

✔ NOTICE: *Condensate must flow freely from the coil at all times to prevent coil damage from water hammer, unequal thermal stresses, freeze-up and/or corrosion. In all steam coil installations, the condensate return connections must be at the low point of the coil. Failure to follow these instructions could result in equipment damage.*

Please remember:

- to support all piping independently of coils.
- To provide swing joints or flexible fittings in all piping connections adjacent to heating coils to absorb expansion and contraction strains.
- Install coils so air passes through fins in proper direction (stenciled on top of coil channel).

⚠ CAUTION!
*Max operating temperature: 400 °F
 Max operating pressure: 72 PSI (5 bar)
 Testing pressure: 290 PSI (20 bar)*

1. Install 1/2-inch 15-degree swing check vacuum breaker in unused condensate return tapping as close as possible to coil. Vent vacuum breaker line to atmosphere or connect into return main at discharge side of steam trap. Vacuum relief is particularly important when coil is controlled by modulating steam supply or two-position (on-off) automatic steam supply valve.
2. Proper steam trap selection and installation is necessary for satisfactory coil performance and service life.
 - a. Select trap based on maximum possible condensate rate and recommended load factors.
 - b. Locate steam trap discharge at least 12 inches below condensate return tapping. This provides sufficient hydrostatic head pressure to overcome trap losses and assure complete condensate removal.



- c. Float and thermostatic traps are preferred because of gravity drain and continuous discharge operation.
 - d. Use float and thermostatic traps with atmospheric pressure gravity condensate return with automatic controls or where possibility of low pressure supply steam exists.
 - e. Bucket traps should only be used when supply steam is unmodulated and 25 psig or higher.
 - f. When installed with series airflow, size traps for each coil using capacity of first coil in airflow direction.
 - g. Always trap each coil separately to prevent condensate holdup in one or more coils.
 - h. Always install strainers as close as possible to inlet side of trap.
3. Use V-port modulating valves to obtain gradual modulating action or slow opening 2-position valves to prevent steam hammer.
 4. Use normally-open non-modulating control valves if coils are exposed to freezing air.
 5. Control each coil bank separately when installing coils for series airflow with automatic steam control valves.
 6. Do not modulate steam or use on-off supply control on systems with overhead or pressurized returns unless condensate is drained by gravity to receiver (vented to atmosphere) and returned to main by condensate pump.
 7. At startup with dampers, slowly turn steam on full for at least 10 minutes before opening fresh air intake.
 8. Pitch all supply and return steam piping down a minimum of one inch per 10 feet in direction of flow.
 9. Do not drain steam mains or take-offs through coils. Drain mains ahead of coils through steam trap to return line.
 10. Do not bush or reduce coil return tapping size. Run return pipe full size of steam trap connection except for short nipple screwed directly into coil condensate connection.
 11. Overhead returns require 1 psig pressure at steam trap discharge for each 2-foot elevation to assure continuous condensate removal.

10 Controls Interface

10.1 Control Options

Air handling units VTS are available without controls or with control options. A standard option of control system can be extended by web-service access module (TCP/IP ModBus).

The main roles of VTS control system are protection and control of supply and exhaust AHUs equipped with:

- two fan sets fitted with frequency converters (up to 10HP),
- mixing box,
- chilled water coil (cooler) and hot water coil (heater),
- optional heat recovery system –heat wheel or cross flow plate exchanger.

without controls or with control options.

The control system consists of:

- control box (with Carel UPC controller and transformer 115V/24V)
- HMI Advanced,
- HMI basic,
- room temperature sensor,
- duct temperature sensors,
- anti-freeze thermostat,
- overheating thermostat,
- motorized valves (for chilled water coils and hot water coils),
- air dampers actuators for mixing chamber air dampers.

Table 36 List of available codes of applications

AHU with cross-flow plate exchanger						AHU with heat wheel						Supply AHU						
Application code		Hot water coil	Chilled water coil	DX cooler	Summer Recovery	Application code		Hot water coil	Chilled water coil	DX cooler	Summer Recovery	Application code		Hot water coil	Chilled water coil	DX cooler	Mixing chamber (economizer)	Summer Recovery
AP	32					AR	0					AS	1	1				
AP	33	1				AR	1	1				AS	4		1			
AP	36		1			AR	4		1			AS	5	1	1			
AP	37	1	1			AR	5	1	1			AS	8			1		
AP	40			1		AR	8			1		AS	9	1		1		
AP	41	1		1		AR	9	1		1		AS	65	1			1	
AP	160				1	AR	128				1	AS	68		1		1	
AP	161	1			1	AR	129	1			1	AS	69	1	1		1	
AP	164		1		1	AR	132		1		1	AS	72			1	1	
AP	165	1	1		1	AR	133	1	1		1	AS	73	1		1	1	
AP	168			1	1	AR	136			1	1	AS	193	1			1	1
AP	169	1		1	1	AR	137	1		1	1	AS	196		1		1	1
												AS	197	1	1		1	1
												AS	200			1	1	1
												AS	201	1		1	1	1

10.2 Control Interface

10.2.1 Control box with controller uPC

The control system with UPC controller and Human Machined Interface offer the combined advantages of simple and dependable operation. Standard control features include options normally available on more elaborate control systems. All control options are available factory pre-configured or can be easily field-configured using HMI Advanced .



Table 37 Mains switch
I = ON, O = OFF

SIGNALLING CONTROLLER STATUS

In the bottom left side of the controller, there are two LED indicators

- **Orange LED** indicates the condition of the power supply. LED off means no power supplied to the terminals or malfunction of internal power supply circuitry. LED on means correct parameters of the power supply.
- **Green LED** indicates the condition of controller's BIOS. LED off means that the firmware is not running correctly. LED on means that BIOS runs OK and the controller is ready for operation.

The unit can be controlled from several sources and the priorities between them has got significant influence on the behavior of the AHU.

✔ **NOTICE!** *The “highest priority” is reserved for important protective functions like fire alarm. Events of that kind disable all other controls to protect life and property.*

- **HMI Advanced UPC** – the main and the most capable interface has got the highest priority. Choosing any mode other than *Auto* causes blocking all the other control sources. The unit will work continuously in selected mode.

✔ **NOTICE!** *Selecting “Off” in the HMI Advanced blocks the unit (unoccupied mode). Only protective functions like freeze protection remain activated.*

To enable any control source of lower priority, the HMI operating mode must be set to **Auto**.

- **BMS** - second highest interface capable of AHU mode change. For the details, refer to special Web Module Manual.

External control inputs – those are configurable binary inputs available for the user depending on the complexity of the control application. Most applications allow for two binary inputs DI6 and DI7. DI6 however, can be occupied by the additional pre-heating coil frost protection.

✔ **NOTICE!** The control mode resulting from external inputs overrides all the settings from the Calendar and HMI Basic UPC

- **HMI Basic UPC** - it is a device with lower priority. HMI Basic can overwrite any operation mode from the calendar (time schedule).
- **Calendar** – lowest priority control source available for the user. If HMI Advanced is set to *Auto* and no other control sources are activated, the unit will work according to specified time schedule.
- **Economy and protection functions** – those the least prioritized automatic functions, activated when the HMI Advanced is set to *Auto* and all other control sources are *Auto*. Those functions are *Night Cooling* and *Standby*.
- **Night cooling** checks the external temperature readout and if the air outside the building is colder than the room setpoint, the fans are turned on in order to cool down the building, the walls and equipment inside. That allows for energy saving by not using the cooler in the morning time.
- **Standby** checks the deviation of controlled temperature and if it goes too much away from desired value, the unit is turned on to cool down or heat up the room – to stay within the specified range. That functionality protects the building and the appliances inside from too big temperature amplitudes across the day.

✔ **NOTICE!** To enable any control source, all other sources of higher priority must be set to *Auto*.

10.2.2 Advanced control panel HMI Advanced UPC

Functions:

- Air handling unit operation, parameterization and maintenance
- Selection of control application
- Time zones setting
- Displaying and canceling alarm statuses, viewing alarm history

Navigation

- **LCD Display**

Displaying available parameters, settings and current values.



- **BELL Button**

Jump to alarm handling pages

- **PRG Button**

1. Quick jump to the Calendar main page
2. In Calendar pages - quick clear of the settings

- **ESC Button**

Jump to the main page or leaving the parameter change

- **UP Arrow**

1. Moving up across the menu screens (when the cursor stays in upper left corner)
2. Increasing the parameter value

- **ENTER Button**

1. Moving the cursor across the screen - cursor jumps to the next parameter available for changing. Read-Only parameters are not marked with the cursor.
2. Confirming entered values
3. Entering sub-menus from the main menu level:
 - Parameters

- Calendar
- Alarms
- Settings
- Service

- **DOWN Arrow**

1. Moving down across the menu screens (when the cursor stays in upper left corner)
2. Decreasing the parameter value

Navigation's example:

1. In the main menu level use UP/DOWN arrows to find the desired sub-menu
2. Press ENTER to go to the sub-menu level
3. Use UP/DOWN arrows to move across the sub-menu screens
4. In the desired screen, use the ENTER button to switch between the changeable parameters - the cursor starts from the upper left corner (which is the base position) and jumps on and on until going back to the upper left corner - then the loop can be started again
5. To change the parameter marked with the cursor, use the UP/DOWN arrows
6. Press ENTER to go confirm the change and to jump further

Parameters available in the LCD window depends on a AHU type and the control application. Hence in AHUs not equipped with heater, options related to the heating module will not be visible. HMI Advanced UPC can't serve as a room temperature sensor. HMI Advanced is an optional element.

MAIN MENU FUNCTIONS

1. Main default screen with most important statuses and setpoints.
 - **Set mode HMI** – is used to set the main operating mode from the HMI.
 - **Current mode** – indicates current AHU mode resulting from HMI setting, alarms, external control signals etc.
 - **Set temp HMI** – is used to enter the main temperature setpoint from the HMI.
 - **Current temp** – temperature readout from the main sensor.
2. Second main status screen
 - **Fans** – indicates the current state and rate of the fans
 - **Dampers** – indicates the current state and opening rate of the dampers
 - **Regulator** – indicates the state and the output of the main controller for heating / cooling function
 - **Recovery** – indicates the state and rate of the heat recovery unit
3. Sub-menu link screen
 - **EN/PL/RU** – language selection
 - **PASSWORD** – is used to enter to special settings and hidden parameters
4. Sub-menu link screen
 - **PARAMETERS** => link to main statuses and readouts from the control system
5. Sub-menu link screen
 - **CALENDAR** => link to calendar settings and time schedule programming
6. Sub-menu link screen
 - **ALARMS** => link to alarm pages
7. Sub-menu link screen
 - **SETTINGS** => link to set and adjust the control system, regulators, timers
 - **SERVICE MENU** => link to main configuration parameters, application codes, AHU startup settings

✓ **NOTICE!** All the menus are dynamically changed, as they depend on the application settings and the password level.

PARAMETERS

PARAMETERS => SUP FAN & DAMPER, EXH FAN & DAMPER.

- *Sup fan setpoint / Exh fan setpoint* – setting for fan rate given in % for Low / Econo / Comfort separately
- *Sup fan rate / Exh fan rate* – indicate the current fan state by showing the percentage of control signal. 0% = fans stopped, >0% = fans running
- *Status* - combined information for communication problems and for motor alarms
- *OK* - no malfunctions
- *Comm* - communication to the frequency converter not stable or lost
- *Alarm* - communication OK, but frequency converter reported an error, e.g. overload
- *Damper opening* - indicates current position of the intake and outlet dampers: 0% = fully closed, 100% = fully opened

✓ **NOTICE!** The fan rate settings cannot exceed Freq. low / high limit settings. If so, they are corrected automatically.

PARAMETERS => HEATING

- *Main temp* – current readout from the main temperature sensor
- *Setpoint* – current setpoint for the regulator, read only
- *Heating rate* – indicates current heating capacity
0% – no heating, 100% – full heating
- *Pump status* – indicates current state of the circulation pump
- *On* - turned on
- *Off* - switched off
- *Alarm status* – indicate the state of frost protection input or overheating protection (for water coil or electrical heater, respectively)
- *Back water* – current readout of the back-water temperature measured on outlet pipe of the heating coil.

PARAMETERS => RECOVERY

- *Recovery mode* - selecting the operation mode for the recirculation chamber

- MECH – Maximum Energy Changeover – control from the PID controller, recirculation plays the role of the first heating / cooling section in order to take full advantage of energy recovery, the scope of possible changes concerning recirculation is defined by fixed setting of minimum fresh air.
 - *Manual* - fixed manual recirculation settings
 - *Univ.AI* – control from the universal analog input; the range of possible changes is limited by the setting of minimum fresh air
- *Recovery rate* – indicates current recovery capacity, gives a link to output detail screen (password protected link)
0% – no recovery, 100% – full recovery

✔ **NOTICE!** The controller signal can differ from the actual recovery rate due to protective functions that could affect it.

- *Frost prot. rate* – indicates the rate of frost protection, that is subtracted from controller signal in order to protect the recovery unit from freezing

✔ **NOTICE!** Freeze protection can be managed in two stages - first step can be reduction of supply fan speed, second step is reducing the recovery rate.

- *Status* - combined information for communication problems and for motor alarms
 - OK - no malfunctions

- Comm - communication to the frequency converter not stable or lost
- Alarm - communication OK, but frequency converter reported an error, e.g. overload

PARAMETERS ==> COOLING

- Main temp – current readout from the main temperature sensor
- Setpoint – current setpoint for the regulator, read only
- Cooling rate – indicates current cooling capacity
0% – no cooling, 100% – full cooling
- Pump status – indicates the current state of the pump or chiller
- Alarm status – indicates the state of the cooling device
 - OK - no malfunctions
 - Fault - alarm input has been activated

PARAMETERS ==> SUP MOTOR, EXH MOTOR

- *Freq* - actual output frequency
- *Current* - actual current consumption
- *Status* - combined information for communication problems and for motor alarms.
 - OK - no malfunctions.
 - *Comm* - communication to the frequency converter not stable or lost.
 - *Alarm* - communication OK, but frequency converter reported an error, e.g. overload.

✔ **NOTICE!** FC details visible only if frequency converters were enabled during unit configuration.

SETTINGS

SETTINGS => TIMERS

- *On-delay* - setting for startup delay, from start command to the actual startup of the unit
- *Idle* - setting for startup procedure, in idle state the fans run at lowest speed, dampers are opening and all the heating/cooling/recovery and protective regulators enter normal operation mode
- *Off-delay* - setting for delayed stopping of the fans, can be used to cool down electric heater or to run down the DX cooling system

SETTINGS => STANDBY

- *Enable* – activate the standby functionality
 - No – function disabled
 - Yes – function enabled
- *Start Htg* – temperature at which the heating is activated
- *Setpoint Htg* – temperature at which the heating is turned off
- *Start Clg* – temperature at which the cooling is activated
- *Setpoint Clg* – temperature at which the cooling is turned off
- *Min work time* – min. running time in standby mode
- *Min delay* – min. resting time after working in standby mode

SETTINGS => NIGHT COOLING

- *Enable* – activate the night cooling functionality
 - No – function disabled
 - Yes – function enabled
- *Min ext temp* – night cooling function is disabled below that limit of external temperature
- *Min work time* – min. working time for the night cooling
- *Min delay* - min. time when the function cannot be enabled again

SETTINGS => NIGHT TEST

- Night cooling and Standby functions rely on room temperature. If there's no temperature measurement in the room, the exhaust duct sensor is taken into account and gives the readout. This requires turning on the fans to refresh the air and have appropriate room temperature value on that sensor.

- *Enable* – activate the night test functionality
 - No – function disabled
 - Yes – function enabled
- *Test hour* – setting the time, when the night test function will be triggered. The night test operates in a daily manner.
- *Test duration* – specifies how long the night test will be executed.

⊙ **NOTICE!** If during the Night Test operation, conditions for Night Cooling or Standby will be detected, the unit will automatically switch to another relevant mode.

⊙ **NOTICE!** Night Test functionality will not be triggered if external temperature is lower than Min Ext Temp for Night Cooling.

SETTINGS => TEMPERATURES

- *Setpoint Hi* – setting for upper boundary of temperature setpoint
Range: 20..40 // Default: 26
- *Setpoint Lo* – setting for lower boundary of temperature setpoint
Range: 0..20 // Default: 16
- *Deadzone LOW*– settings for the allowed non-sensitive range in Low mode
Range: 0..10 // Default: 4.0
- *Deadzone ECO*– settings for the allowed non-sensitive range in Econo mode
Range: 0..10 // Default: 2.0
- *Deadzone COMF*– settings for the allowed non-sensitive range in Comfort mode
Range: 0..10 // Default: 1.0
- *Min Clg temp* – setting for the temperature limit. If external temperature falls below that value, the cooling functionality is disabled.
Range: 0..20 // Default: 16

SETTINGS => FANS

- Supply freq limits Min / Max
- Exhaust freq limits Min / Max
- Limits in Hz for allowed range of operation

⚠ **CAUTION!** The fan rate settings cannot exceed Freq. low / high limit settings. If so, they are corrected automatically.

SETTINGS => WATER HEATER

- Pump start temp – setting for the temperature limit, that forces the pump to continuous operation for initial freezing protection
- Range: -10..20 // Default: 5
- Pump kick – timer that forces the circulation pump to run for short period of time (30s) in specified intervals. That prevents the mechanical sealings from sticking and damage.
- Range:
 - No - function disabled
 - Day - function activated daily
 - Week - weekly
 - Month – monthly

SETTINGS => RECOVERY UNIT

- After reco setp - setpoint for minimal allowed temperature after the recovery units PCR, RRG or glycol turnaround coils
Range: -64..64 // Default: 3.0
- Min. fresh air – setting for min. opening of intake / outlet dampers to provide fresh air in the ventilated room
Range: 0..100% // Default: 30%
- Manual mode - setting fixed values of recirculation for Hand and Hand.Multi modes
Range: 0 100% // Default: 30%

SETTINGS => DX COOLER

- On / Off for stage I and for stage II - settings for the relation between cooling regulator and DX unit stages
- Min work – setting for the min. working time for each stage
Range: 10..600s // Default: 30s
- Min rest – setting for the min. resting time for each stage
Range: 10..600s //Default: 30s

SETTINGS => FAN PI REGULATOR

- Recovery frost protect - special PI regulator to manage supply fan speed reduction in case of freezing conditions. If the limit temperature is reached, the regulator reduces the frequency converter output by specified max. value in Hz
 - Kp - proportional gain
 - Ti - integrational time
 - Ymin - min. value of subtracted frequency (no frost protecting action) - fixed at 0Hz

- Ymax - max. value of subtracted frequency (max. frost protecting action)
Range: 0..50Hz // Default: 5Hz
- Parametric volume control – special regulator for automatic adjustment of the fan speed according to external measurement of flow or pressure. The input
 - Kp - proportional gain
 - Ti - integrational time
 - Ymin - min. value – fixed at min fan rate setting
 - Ymax - max. value – limited by fan rate setpoint for current mode Low / Econo / Comfort
 - Setpoints Low / Econo / Comfort – setpoints for each mode

SETTINGS => TEMP PI REGULATORS

- There are altogether 9 regulators for temperature control. Mostly all of them allow for the same adjustments:
 - Kp - proportional gain
 - Ti - integrational time
 - Ymin - min. value ofr the output
 - Ymax - max. value of the output
- The regulators are:
 - Min sup temp – regulator of min. supply temperature limit
 - Max sup temp – regulator of max. supply temperature limit
- Heating – regulator for main heater
- Recovery – regulator for recovery unit
- Frost protection – regulator for recovery unit protection in winter conditions
- Cooling – regulator for cooler

SETTINGS => MANUAL MODE

- Manual operation – override the inputs and output
- Auto – cancel override
- other states – select to force the inputs or outputs, values depend on the output type

DI1..DI7 - digital inputs - select Auto / On / Off

✔ **NOTICE!** For states different from NULL, an alarm is triggered, the HMI operating mode is forced to Off and AHU cannot be started. Manual mode is intended only for testing purposes.

✓ **NOTICE!** For any overridden states, an alarm is triggered, the HMI operating mode is forced to Off and AHU cannot be started. Manual mode is intended only for testing purposes. Always observe the unit for unintended unsafe operation when using manual mode!

- *B1..B7* - temperature probe inputs - select Auto / -20 / -10 / 0 / 10 / 20 / 30
- *NO1..NO7* - digital outputs - select Auto / On / Off
- *Y1..Y3* - analog outputs - select Auto / 0 / 20 / 40 / 60 / 80 / 100

SETTINGS => INPUT OFFSET

Offset to correct the stable additive error, e.g. from very long sensor cable

SETTINGS => FREQ CONV RRG

- *Freq* - actual output frequency
- *Current* - actual current consumption
- *Status* - combined information for communication problems and for motor alarms

- *OK* - no malfunctions
- *Comm* - communication to the frequency converter not stable or lost
- *Alarm* - communication OK, but frequency converter reported an error, e.g. ov
- *Freq. low limit* – lower boundary of the frequency
Range: 10..25HZ // Default: 15Hz
- *Freq. high limit* – upper boundary of the frequency
Range: 35..65Hz // Default: 55Hz

SETTINGS => FANS FIRE MODE

Settings for the fan behavior when there's a fire alarm signal

- *Sup fire setp* - 0..100% - setpoint for fan rate in fire conditions, 0% = fan stopped
- *Exh fire setp* - 0..100% - setpoint for fan rate in fire conditions, 0% = fan stopped
- *Fire temp limit* - setpoint for the supply and exhaust duct temperature that triggers the alarm signal
Range: 60..99 // Default: 99

10.2.3 Simplified control panel - HMI Basic UPC

Functions:

- Room temperature measurement and display
- Change and display of temperature setpoint
- Change and display of fan setpoint
- Display temperature of the main control sensor
- Change of AHU operation mode
- Info on alarm status

HMI Basic is an optional element that is connected with the controller through the Modbus line, common with the frequency converters.

• LCD Display

Indicates actual room temperature or temperature on the main control sensor as well as a chosen setting, operation mode, fan speed, time and day of the week.



• ON/OFF button

Switching between On/Off state (forcing the unit to stop or enabling operating mode selection)

CALENDAR MODE IN HMI BASIC

HMI Basic can operate with time schedules in two ways. Selection is done in Service Menu of the μ PC controller and is available only via HMI Advanced interface.

- HMI Basic can use the calendar in the controller – all settings are done via HMI Advanced or via BMS connection and HMI Basic can only activate / deactivate operation according to time schedule stored in the controller.

✓ **NOTICE!** HMI Basic cannot change any settings in the controller's calendar.

• Fan button

Button for mode setting: Auto / Low / Econo / Comfort

• Clock button

Entering Auto mode. Controller will operate according to the time schedule stored in Calendar settings.

Note! There are two options for time schedule operation. For details, follow chapters related to Calendar and to Service Menu.

Note! If the Calendar is also in Auto mode, the AHU operation will rely only on protective and energy saving functions like Standby and Night Cooling. This is possible for the main Calendar of the controller. The built-in Calendar of the HMI Basic doesn't support that functionality.

• Push & Roll knob

- Quick, intuitive and easy entering values, changing setpoints, accepting new values.
Note! To change the temperature set-point, just turn the knob.
- Display of the room sensor temperature or the value of the temperature setpoint
Note! Setting is limited to 60.8.. 78.8 °F (16..26°C) Icons for active recirculation, cooling or heating
- Time indication.
- Display of the fan speed setting or the indication of automatic fan mode
- Indications of the weekdays
- Icon for active recovery unit
- Icon for alarm event
- Icon for Off mode

- HMI Basic can use own local time scheduler – all the settings are done and stored in HMI Basic.

✓ **NOTICE!** Mind the limitations of the HMI's calendar – only On/Off and temperature settings can be adjusted in the HMI Basic. Low / Econo / Comfort modes must be pre-set in the controller settings via HMI Advanced.

Setting the program for selected days:

1. Clock button - long-press to enter settings mode
2. Turn the knob to select "Time band" and press to enter
3. In "Sel days" turn the knob to select days - whole week, working days, weekend, or any day separately. Then press to enter.
4. Observe the house icon - it indicates which time zone is edited at the moment. Turn the knob to select specific time zone from 1 to 6. Press to enter.
5. Turn the knob to set hour and press to confirm.

6. Turn the knob to set minutes and press to confirm.
7. Turn the knob to set the temperature and press to confirm.

✔ **NOTICE!** Between 23 and 00 there's blank setting --:-- which means, that current time zone is skipped.

✔ **NOTICE!** Below minimum setpoint there's OFF setting. Use that to turn off the unit in selected time zone.

To leave from any level of calendar programming, select ESC and press to confirm. To set clock, long-press the Clock button to enter settings mode, turn the knob to select Clock, press to enter and set proper hour, minutes and weekday.

✔ **NOTICE!** Setting the weekday properly is necessary for correct operation of the Calendar mode.

10.2.4 WEB-SERVER OPTION (TCP/IP Modbus)

WEB-SERVER OPTION gives extended access to read / write parameters like measurement readouts, setpoints, settings, output values, selected calendar settings, alarms. Total count of available parameters exceeds 200 datapoints.

Note: SEE SPECIAL MANUAL FOR DETAILS OF EXPANSION CARD OPERATION

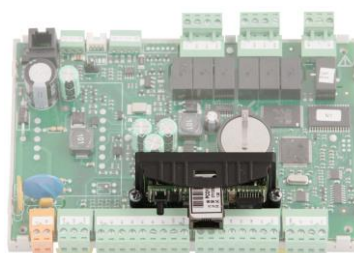

10.3 Controller Service Mode

The HMI Advanced and HMI Basic allow field service personnel to easily monitor, save, download and configure



Many parameters are protected with a password, to avoid unintentional change, that could be dangerous for the unit or for the user. To access that parts of the menu, a password must be entered.

Note: Default password is: 1357

The access to the service mode is available in PASSWORD function in HMI Advanced.

The PASSWORD is hidden in the second level of menu.

The PASSWORD function is used to enter to special settings, hidden parameters and cancellation of alarms.



11 Pre-Start

Pre-Start Checklist

Complete this checklist after installing the unit to verify all recommended installation procedures are complete before unit startup. This does not replace the detailed instructions in the appropriate sections of this manual. Disconnect electrical power before performing this checklist. Always read the entire section carefully to become familiar with the procedures

Receiving

- Inspect unit and components for shipping damage. File damage claims immediately with the delivering carrier.
- Check unit for missing material. Look for ship-with drives, isolators, filters, and sensors that are packaged separately and placed inside the main control panel, fan section, or compressor section (see “Receiving and Handling,”).
- Check nameplate unit data so that it matches the sales order requirements.

Unit Location

- Remove crating from the unit. Do not remove the shipping skid until the unit is set in its final position.
- Ensure the unit location is adequate for unit dimensions, ductwork, piping, and electrical connections.
- Ensure access and maintenance clearances around the unit are adequate. Allow space at the end of the unit for shaft removal and servicing (see “Service Access,”).

Unit Mounting

- Place unit in its final location.
- Remove shipping skid bolts and skid.
- If using isolators, properly mount unit according to the isolator placement sheet.

Component Overview

- Ensure the fan rotates freely in the correct direction.
- Verify that a clean air filter is in place.

Ductwork

- If using return ductwork to the unit, secure it with three inches of flexible duct connector.
- Use a 3” flexible duct connection on discharge ductwork.
- Ensure trunk ductwork is complete and secure to prevent leaks.
- Verify that all ductwork conforms to NFPA 90A or 90B and all applicable local codes.

Unit Piping

- Verify the condensate drain piping is complete for the unit drain pan. Install and tighten the condensate “P” trap drain plug.
- Make return and supply water connections to the unit and/or piping package.
- Ensure the drain pan and condensate line are not obstructed. Remove any foreign matter that may have fallen into the drain pan during installation.
- Verify that piping does not leak. Make sure drain lines are open while performing the leak test.
- Treat water to prevent algae, slime, and corrosion.
- Connect refrigerant piping lines.
- Connect steam supply line, condensate return line, and vacuum breaker line to coil in accordance with steam piping recommendations

Electrical

- Check all electrical connections for tightness.
- Verify motor voltage and amps on all phases with the unit nameplate ratings to ensure unit operates correctly.

Unit Panels

- Ensure all unit access panels are in place and that all screws, nuts, and bolts are tightened to their proper torques.

⊙ **NOTICE!** During the unit break-in period, bearing temperature may be 150°F–160°F. during normal operation bearing temperature should range be 90°F–100°F.



12 Start-Up

12.1 Sequence of Operation

✔ **NOTICE!** Operation of the AHU is strictly arrested by the fire-protection alarm, activation of the thermal protection of fans' motors, threefold activation of the protection of electric heater and threefold activation of the anti-frost thermostat. Each of these events requires removing the cause of the alarm and then canceling it. Switching on power supply.

✔ **NOTICE!** The system is ready for operation after about half minute from switching on.

✔ **NOTICE!** If the system did not start, check the F1 protection status. Correct device operation depends on the application settings. Choosing and setting up the application should be done by qualified service provider.

For startup of Ventus air handling unit:

1. **Turn on the power supply for variable frequency drives.**

✔ **NOTICE!** That circuits are separate from the control box CBX UPC supplied by VTS!

2. **Turn on the main switch of the control box CBX UPC.**

✔ **NOTICE!** It takes approximately 40 seconds for the controller to do self-testing and BIOS starting procedure!

3. **Select desired working mode of the unit, using either the HMI Advanced or HMI Basic.**

4. **Then the unit starts, according to previously programmed settings (refer to the *UPC Programming Guide* for details).**

In some circumstances, reaching the desired operating mode can take several minutes. Observe the main screen of the HMI Advanced to see the mode, that is actually active.

⚠ **CAUTION!** The control box of VTS, provides not only air handling algorithms. It can manage protective functions like anti-freezing protection for hot water coil. In case of the freezing alarm, the controller will take action to protect the air handling unit and its equipment. Therefore, the power supply for the control box CBX UPC and for VFDs should always remain **TURNED ON**.

⚠ **CAUTION!** Turn off the power supply only for personal safety reasons, when doing service, cleaning or overhaul works!



SELECTION OF OPERATING MODE– HMI Advanced

Enter: Main menu / Set mode HMI / and one of the options: Auto..Off..Low..Econo..Comfort

The AHU can operate in one of the following operating modes:

Auto - The AHU operates depending on one of the options

- the calendar programming,
- HMI Basic,
- external control signals (binary inputs)
- critical temperatures, e.g. too low temperature causes AHU start and immediate heat-up of the room

Low - The lower economy mode

The fan speed and the deadzone for temperature regulation are adjustable
The temperature control algorithm can use broad deadzone and the fans can be set to low speed in order to reduce energy consumption

Econo - The upper economy mode.

The fan speed and the deadzone for temperature regulation are adjustable
The temperature control algorithm can use narrower deadzone and the fans can be set to higher speed in order to optimize energy consumption

Comfort – *Comfort mode*

The fan speed and the deadzone for temperature regulation are adjustable
The temperature control algorithm can use most accurate deadzone and the fans can be set to highest speed in order to give maximum comfort

☑ **NOTICE!** The temperature setpoint is common for all operating modes, the deadzone settings are individual for each mode.

SELECTION OF OPERATING MODE – HMI BASIC

1. **On/Off button** - press to switch between Off and Low mode.
2. **Fan button** - press to switch operating mode between Low - Econo - Comfort

3. **Clock button** - press shortly to switch to Auto mode. In Auto mode Calendar will be capable of taking over the control.

INDICATION OF OPERATING MODE in HMI Advanced

The following modes can be displayed in Current mode field in the main menu:

Auto..Off..Low..Econo..Comfort as described above

Fire – operating mode enabled by fire alarm input. All the devices switched off, the fans stop or run with selected setpoint (see chapter Service Menu)

NightClg – Night Cooling – a mode for energy saving by cooling down the room using cold air from the outside in the night. Available only in the units with external temperature sensor.

Standby – protection mode for min/max room temperature – if the temperature exceeds specified setpoints, AHU is switched on, to heat up or cool down to desired range. Then switches off again.

NightKick – testing mode, that forces fans to run in order to exchange the air in the ventilation system.

☑ **NOTICE!** Night cooling and Standby functions rely on room temperature. If there's no measurement in the room, the exhaust duct sensor is taken into account and gives the readout. This requires turning on the fans to have appropriate room temperature value on that sensor.

Startup - temporary mode when dampers are opening, fans speed up and the heating / cooling devices are enabled and start operation.

Heating - mode when heaters can be enabled

Cooling - mode when coolers can be enabled

Vent - Ventilation - energy saving mode, when neither heaters nor coolers are enabled and the unit operates only with ventilation and optional recovery unit.



EmgStop - Emergency Stop - unit forced to stop immediately, according to signal from optional digital input.

AlrStop - Alarm Stop - unit forced to stop because of an alarm

CrtStop - Critical Stop - unit forced to stop because of a critical alarm

Config - unit forced to stop because the controller is in the “Config” mode. The controller must be configured first and switched to the **Running** mode.

The function “Off” switched AHU off (fans stopped, control valves closed, all sensors and gauges are activated – in order to protect the unit from damage, e.g. fire alarm, frost protection.

12.2 UPC Controller Sequence of Operation

OPERATING MODE

The unit can be controlled from several sources and the priorities between them has got significant influence on the behavior of the AHU.

✔ **NOTICE!** The “highest priority” is reserved for important protective functions like fire alarm. Events of that kind disable all other controls to protect life and property.

HMI Advanced UPC – the main and the most capable interface has got the highest priority. Choosing any mode other than Auto causes blocking all the other control sources. The unit will work continuously in selected mode.

✔ **NOTICE!** Selecting Off in the HMI Advanced blocks the unit. Only protective functions like frost protection remain activated.

To enable any control source of lower priority, the HMI operating mode must be set to Auto.

BMS - second highest interface capable of AHU mode change. For the details, refer to special Web Module Manual.

External control inputs – those are configurable binary inputs available for the user depending on the complexity of the control application. Most applications allow for two binary inputs DI6 and DI7. DI6 however, can be occupied by the additional pre-heating coil frost protection.

The control mode resulting from external inputs overrides all the settings from the Calendar and HMI Basic UPC

HMI Basic UPC - it is a device with lower priority. HMI Basic can overwrite any operation mode from the calendar (time schedule).

Calendar – lowest priority control source available for the user. If HMI Advanced is set to Auto and no other control sources are activated, the unit will work according to specified time schedule.

Economy and protection functions – those the least prioritized automatic functions, activated when the

HMI Advanced is set to Auto and all other control sources are Auto. Those functions are Night Cooling and Standby.

Night cooling checks the external temperature readout and if the air outside the building is colder than the room setpoint, the fans are turned on in order to cool down the building, the walls and equipment inside. That allows for energy saving by not using the cooler in the morning time.

Standby checks the deviation of controlled temperature and if it goes too much away from desired value, the unit is turned on to cool down or heat up the room – to stay within the specified range. That functionality protects the building and the appliances inside from too big temperature amplitudes across the day.

✔ **NOTICE!** To enable any control source, all other sources of higher priority must be set to Auto.

STARTUP SEQUENCE

✓ **NOTICE!** Switching on power supply of the control box with the mains switch (Q1M). Correct power supply and good BIOS operation is indicated by yellow and green LED lamps on the controller's PCB.

The startup sequence ensures proper order of enabled functions. The main startup operations are:

1. Power up delay – fixed 20s - the timer that delays the startup of the unit after switching on the power. That delay gives time for all devices for reaching stable initial state (e.g. frequency converters and communication)
2. Initial heating – function of initial heat-up of the water coils in wintertime, according to specified timers and valve opening rate. The preheating disables the fans and dampers until finished. The valve opening rate of initial heating stage, is copied as a starting point for the regulator of normal heating mode. This minimizes the risk of accidental frost protection alarms between the stages of unit startup.
3. Idle operation – dampers are opening, regulators are enabled and controlling the outputs, while fans are running at the minimum speed and the supply air upper temperature limit is forced to 40°C to allow smooth ventilation and heating start after initial heating stage.
4. Fans ramp-up time – specifies the rate of acceleration for the fans.
5. Idle at stop - allows for smooth stop of the DX cooling appliance.

✓ **NOTICE!** Some alarm events can block the startup of the unit.

COOLING / RECOVERY / HEATING

Using signals:

1. Temperature measurements
2. Alarm signals
3. Outputs for actuators

The purpose:

Heat exchangers in the AHU cooperate to keep the temperature in specified range. Three separate ranges can be defined for Low, Economy and Comfort mode – with common

setpoint, but with separate deadzone for each. The range is defined as the setpoint \pm ½ deadzone.

Example:

setpoint: 69.8°F, comfort deadzone: 3.6°F - resulting range: 68..71.6°F

setpoint: 69.8°F, economy deadzone: 10.8°F - resulting range: 64.4..75.2°F

setpoint: 69.8°F, low deadzone: 14.4°F - resulting range: 62.6..77°F.

The ranges are selected depending on the current operating mode of the controller. If the actual temperature is within the range – the unit will remain in current state – so the cooling / recovery / heating signals will stay in equilibrium. If the actual temperature is above the range – the unit will increase in cooling. If it's below the range – the unit will increase in heating. What should be noted, the first sequence of cooling / heating is performed by the heat recovery unit to maximize the utilization of the energy generated in the building. If the recovery capacity is not enough, then the cooler or heater starts to operate to supply more energy to the unit.

NOTICE! The recovery can be active together with cooling or with heating sequence. However, the cooling and heating cannot be active at a time under any circumstances.

The recovery for heating is active by default. For cooling this must be activated by specific application code number.

Protective functions:

1. **Min/max supply air temperature**
If the main temperature sensor is selected room or exhaust, the supply temperature is controlled against over-heating or over-cooling. This could seriously affect the comfort of the people in the room. The min/max controller has higher priority than main temperature control loop.
2. **Cooling sequence** is protected with Chiller / DX Unit binary alarm input. If activated: the AHU remains working, but the cooling demand relays and analog signal for the valve are turned off
Doesn't need to be acknowledged, the alarm is of non-remanent type
3. **Recovery sequence** is protected against freezing
If the temperature measurement in the exhaust duct after the recovery unit, fall below the specified protection setpoint, the rate of the recovery is being reduced. The reduction is controlled by PI controller, so it

is always the least necessary value to protect the recovery unit, but without excessive degrading the recovery efficiency.

The first stage of recovery anti-freezing protection is reducing the fan speed for the supply (or supply and exhaust synchronously). After the maximum allowed fan slowing down, the recovery unit can apply own protective functions (bypassing of the plate cross-flow heat exchanger, reducing the RPM of rotary recuperator, closing the intake damper for non-bypass plate cross-flow exchangers in VS10-15 units).

The recovery protection does not affect the AHU operation. All other devices continue to work even if the recovery rate is reduced to 0% by protective functions.

4. Heating sequence:

- a. Initial heating – is a start-up feature enabled in winter, to avoid passing cold air to the room and to avoid activating the water heater frost protection at start-up. The specified time and valve opening characteristic is applied in order to properly heat-up the coil and the coil compartment before starting the fans. The startup of the AHU is blocked until the preheating is finished. During initial heating, the heat recovery unit is automatically forced to 100% efficiency.
- a. Frost protection on the air side – uses a digital alarm input to connect the

frost detector. If activated, the fans are stopped, dampers closed and the valve is forced to open at full 100% heating rate. After the detector switches back to normal mode, the startup of the AHU is performed again.

✔ **NOTICE!** The automatic release of the frost protection on the air side can be done max. 3 times per hour. If that happens more often the controller is locked in stop mode and the AHU cannot be started until fixing the malfunction and acknowledge the alarm.

✔ **NOTICE!** The counter is disabled if the AHU is in Off mode, e.g. stopped for the night. The frost protection will work continuously just to protect the coil and ensure proper temperature in coil's compartment.

- b. Pump kick – is a timer to turn on the pump for the very short period of time, to prevent it from sticking and damaging the sealing.
- c. Pump min. out temperature – turns on the pump for constant working if the external temperature falls below the specified limit – regardless of heating rate.

13 Maintenance

13.1 Maintenance Procedures.

Perform the following maintenance procedures to ensure proper unit operation.

Air Filters

Always install filters with directional arrows pointing toward the fan. For units with high efficiency filters (MERV 8 or MERV 13), the filters need to be replaced with equivalent MERV-rated filters to maintain unit performance.

Fan Bearings

Fan bearings are permanently sealed and lubricated and do not require additional lubrication.

Fan Motors

Inspect fan motors periodically for excessive vibration or temperature. Operating conditions will vary the frequency of inspection.

****WARNING! Hazardous Voltage!****

Disconnect all electric power, including remote disconnects before servicing. Follow proper lockout procedures to ensure the power can not be inadvertently energized. Failure to disconnect power before servicing could result in death or serious injury.

Fans

Fans are designed for transferring dust-free or light-dusted air. They are not designed for aggressive gases, steams or heavy-dusted air. Operating the fan in not suitable environment can lead to damage of bearings, corrosion, unbalanced rotor or vibrations.

The fan and motor in the unit are designed for particular requirements and operation characteristics. Fan rotation speed is adapted so as the air stream and complete fan stress concentration were appropriate for a given ventilation system. Smaller stream of forced air results in disturbances in correct operation and leads to loss of balance of the entire ventilation system. It can be caused by:

- dust settlements on the fan's rotor blades,
- incorrect direction of fan's rotations. If the centrifugal fan rotates in incorrect direction, the air flow is carried out with significantly deteriorated output.

In case of fan maintenance activities check if:

- the rotor rotates freely,
- the rotor is well balanced,
- the rotor is firmly mounted on pivot,
- did not change a location against the inlet funnel,
- vibro-isolators are firmly installed and they are not damaged,
- flexible connection (if any) is not damaged,
- all screws fastening construction elements of the fan unit are tight.

Electric heater

Electric heater's battery consists of bare heating coils. During AHU operation, when the heater does not work, dust may settle onto the heating coils. Once the heater is turned on again, strong contamination may cause smell of burning dust or even preliminary fire danger may appear.

Check regularly (every year) and especially before starting a heating period, any electric connections, condition of heating elements and their contamination level. Any possible contamination should be removed with a vacuum cleaner with soft suction nozzle or with compressed air.

Also check operation of overheating protection in case of lack of air-flow. Air speed should not be lower than 295 FPM.

 **WARNING! Wet cleaning of electric heater is forbidden!**

13.2 Coil Maintenance

☑ NOTICE!

Potential Unit Damage from Coil Cleaners!
Do not use acidic chemical coil cleaners. Also, do not use alkaline chemical coil cleaners with a pH value greater than 8.5 (after mixing) without using an aluminum corrosion inhibitor in the cleaning solution. Using these types of cleaners could result in equipment damage.

Keep coils clean to maintain maximum performance. For operation at its highest efficiency, clean the coil often during periods of high demand or when dirty conditions prevail. Clean the coil a minimum of once per year to prevent dirt buildup in the coil fins, where it may not be visible. Remove large debris from the coils and straighten fins before cleaning. Remove filters before cleaning. Rinse coils thoroughly after cleaning. Clean the coil fins using one of these methods:

- steam with detergent
- hot water spray and detergent
- commercially available chemical coil cleaner

Inspecting and Cleaning Coils

Coils become externally fouled as a result of normal operation. Dirt on the coil surface reduces its ability to transfer heat and can cause comfort problems, increased airflow resistance and thus increased operating energy costs. If the coil surface dirt becomes wet, which commonly occurs with cooling coils, microbial growth (mold) may result, causing unpleasant odors and serious health-related indoor air quality problems.

Inspect coils at least every six months or more frequently as dictated by operating experience. Cleaning frequently is dependent upon system operating hours, filter maintenance, and efficiency and dirt load. Follow is the suggested method below:

Steam, Hot Water, and Cooling Coil Cleaning Procedure

⚠ WARNING! Hazardous Chemicals!

Coil cleaning agents can be either acidic or highly alkaline. Handle chemical carefully. Proper handling should include goggles or face shield, chemical resistant gloves, boots, apron or suit as required. For personal safety refer to the cleaning agent manufacturer's Materials Safety Data Sheet and follow all recommended safe handling practices. Failure to follow all safety instructions could result in death or serious injury.

1. Don the appropriate personal protective equipment (PPE).
2. Gain access to the coil section.
3. Use a soft brush to remove loose debris from both sides of the coil.
4. Use a steam cleaning machine, starting from the top of the coil and working downward. Clean the leaving air side of the coil first, then the entering air side. Use a block-off to prevent steam from blowing through the coil and into a dry section of the unit.
5. Repeat Step 4 as necessary. Confirm that the drain line is open following completion of the cleaning process.
6. Allow the unit to dry thoroughly before putting the system back into service.
7. Straighten any coil fins that may be damaged with a fin rake.
8. Replace all panels and parts and restore electrical power to the unit.
9. Ensure that contaminated material does not contact other areas of the unit or building. Properly dispose of all contaminated materials and cleaning solutions.

Winterizing the Coil

Make provisions to drain coils that are not in use, especially when subjected to freezing temperatures. To drain the coil, first blow out the coil with compressed air. Next, fill and drain the tubes with full-strength ethylene glycol several times. Then drain the coil as completely as possible.

⚠ NOTICE! Potential Coil-Freeze Condition!
Make provisions to drain the coil when not in use to prevent coil freeze-up. Failure to follow this procedure could result in equipment damage.

13.3 Heat recovery – heat wheel and cross-flow plate exchangers.

✓ **NOTICE!**

Potential Unit Damage from Cleaners!

Do not use acidic chemical coil cleaners. Also, do not use alkaline chemical coil cleaners with a pH value greater than 8.5 (after mixing) without using an aluminum corrosion inhibitor in the cleaning solution. Using these types of cleaners could result in equipment damage.

Heat recovery – heat wheel and cross-flow plate exchangers.

Keep heat wheel and cross-flow plate exchanger clean to maintain maximum performance. For operation at its highest efficiency, clean the exchangers often during periods of high demand or when dirty conditions prevail. Clean the exchangers a minimum of once per year to prevent dirt buildup in the coil fins, where it may not be visible. Remove large debris from the coils and straighten fins before cleaning. Remove filters before cleaning. Rinse coils thoroughly after cleaning. Clean the coil fins using one of these methods:

- steam with detergent
- hot water spray and detergent
- commercially available chemical coil cleaner

Heat wheel

 **WARNING! Hazardous Voltage!**

Disconnect all electric power, including remote disconnects before servicing. Follow proper lockout procedures to ensure the power can not be inadvertently energized. Failure to disconnect power before servicing could result in death or serious injury.

Check the exchanger every four months and inspect its technical condition as well as contamination level of the rotor. During

maintenance activities of the rotary exchanger check if:

- rotor rotates freely. Sensible resistance can be caused by too excessive hold down of sealing brushes and touching the rotor's edges. In such a situation adjust the brushes properly. Worn out brushes sealing should be replaced. If previously removed brush sealing is to be installed again, it should be installed so that its direction should be in line with the rotor's rotation direction. After replacement or adjustment of sealing brushes, the exchanger should operate 30 minutes so that the brushes could adapt to the rotor's surface. After this time check the motor's current and compare it with the rated current in order to find out if the motor is not overloaded.
- drive belt is not damaged and if it is clean as well as if it does not slip on the cylindrical part of the rotor. If despite maximal tension by the strain system the clearance still exists, the belt should be replaced or shortened,
- air inlet holes are not covered with dust or contaminated in any other way. In order to clean the rotor apply one of the methods designed for other exchangers.

Rolling bearings of rotor and drive motor are greased in continuous manner during operation. Amount of grease in bearings during the exchanger assembly is enough for long-lasting operation and there is no need to lubricate the bearings during operation. It is recommended to clean the motor and gear from dust so as an insulation layer was not formed on the motor's surface which may lead to increase of drive operating temperature.



13.4 Periodic Maintenance Checklists

The following check list provides the recommended maintenance schedule to keep the unit running efficiently.

⚠ WARNING! Rotating Parts!
Secure drive to ensure motor cannot freewheel. Failure to follow this procedure could result in death, personal injury or equipment damage.

⚠ WARNING! Hazardous Voltage!
Disconnect all electric power, including remote disconnects before servicing. Follow proper lockout/ tagout procedures to ensure the power can not be inadvertently energized. Failure to disconnect power before servicing could result in death or serious injury.

Monthly Checklist

1. Inspect unit air filters. Clean or replace if airflow is blocked or if filters are dirty.
2. Inspect the coils for dirt build-up. Clean fins if airflow is clogged.
3. Measure the current absorbed by the unit.

Semi-Annual Maintenance

1. With power disconnected, manually rotate the fan wheel to check for obstructions in the fan diaphragm or interference with fan blades. Remove any obstructions and debris.
2. Inspect the coils, cross-flow plate exchanger, heat wheel for dirt build-up. Clean fins if airflow is clogged.

Annual Maintenance

Check and tighten all set screws, bolts, locking collars and sheaves.

1. Inspect, clean, and tighten all electrical connections and wiring.
2. Visually inspect the entire unit casing for chips or corrosion. Remove rust or corrosion and repaint surfaces.
3. Clean fan wheels. Remove any rust from the fan shaft with an emery cloth and recoat with L.P.S. 3 or equivalent.
4. Inspect the drainpan for sludge or other foreign material. Clear the drain openings and drain line to ensure adequate flow.
5. Rotate the fan wheel and check for obstructions in the fan diaphragm. The wheel should not rub on the fan diaphragm.
6. Examine flex connector for cracks or leaks.
7. Repair or replace any damaged duct material.

14 Troubleshooting

The HMI Advanced and HMI Basic allow field service personnel to easily monitor, save, download, and configure. The operational status of the controller is displayed in HMI Advanced and HMI BASIC. (See the section 10.2 **Control Interface**)

Alarm in HMI Basic

Alarm in HMI Basic are displayed instead of time indication in a form of a letter and number, like AL15. The number is given to identify what is the source of alarm.

☑ **NOTICE!** HMI Basic cannot acknowledge alarms. All occurred and non-remained events will disappear automatically. All remained events need to be reset by means of HMI Advanced, or by switching off / on the power supply.

List of alarm codes:

AL01. Fire alarm
AL02. HW thermostat
AL07. Supply sensor
AL08. Exhaust sensor
AL09. Room sensor
AL10. Aft.Reco sensor
AL11. External sensor
AL15. SupFan1 comm
AL19. SupFan1 overload
AL23. ExhFan1 comm
AL27. ExhFan1 overload
AL31. Manual mode
AL32. HMI Basic init
AL33. HMI Basic comm
AL34. HMI Adv.init
AL35. HMI Adv.comm
AL36. Modbus init
AL37. Modbus comm

AL38. BMS init
AL39. BMS comm
AL40. Chiller
AL41. Sup filters
AL42. Exh filters

Alarm in HMI Advanced

ALARM MENU ==>

Alarm menu can be accessed through dedicated button on the HMI Advanced

- **NAME** – description of the feature or function that was in alarm state, e.g. Modbus comm
- **STATUS** – current condition of the alarm, OK – inactive, ALARM – active
- **TYPE** – defines the group of alarm events – Normal – these are mostly non-remanent alarms of lower priority; Critical – these are mostly remanent alarms of higher priority, that could even stop and block the unit from further operating.
- **DATE / TIME** – time stamp when the alarm occurred

☑ **NOTICE!** To acknowledge the alarm currently displayed on the HMI, press PRG button. Another way of cancelling the alarms is turning the power Off and On again. At startup all alarms are cleared, except of those, that are still activated by input signals.

☑ **NOTICE!** Alarms can be remained – they are locked until fixed and acknowledged, e.g. the fire alarm or can be non-remained – they unlock, when the alarm signal is fixed and don't need to be acknowledged to go to the history records, e.g. the filter alarm.

15 Wiring Diagrams

15.1 Connection the mains supply with frequency converters.

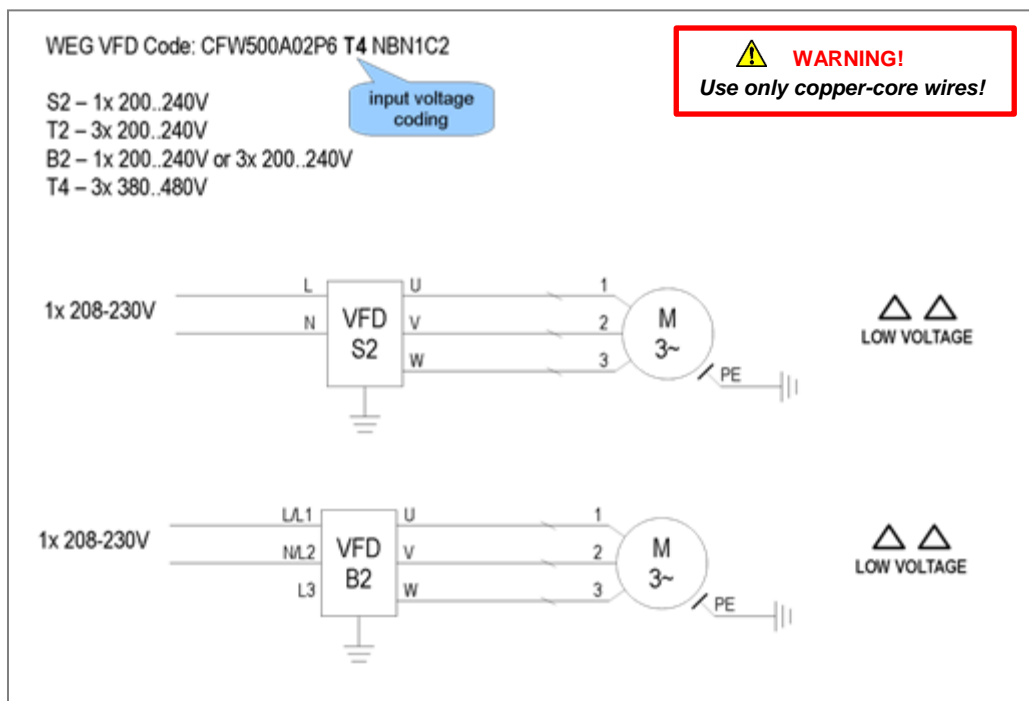

Fig. 45 Connection of 1ph frequency converters

WARNING!

Proper Field Wiring and Grounding Required!

All field wiring **MUST** be performed by qualified personnel. Improperly installed and grounded field wiring poses **FIRE** and **ELECTROCUTION** hazards. To avoid these hazards, you **MUST** follow requirements for field wiring installation and grounding as described in **NEC** and your local/state electrical codes. Failure to follow code could result in death or serious injury

WARNING!

Before starting connecting power supply, check conformity of the voltage and frequency of a supply network with the data shown on the device's rating plate. Permissible fluctuation of the supply voltage and its frequency to the values shown on the rating plate is $\pm 5\%$. If discrepancy exists, the device cannot be connected.

WARNING!

Correct Phase Critical!

Correct phase sequence is critical. If phase sequence of the incoming line voltage is not correct, it could cause motor damage

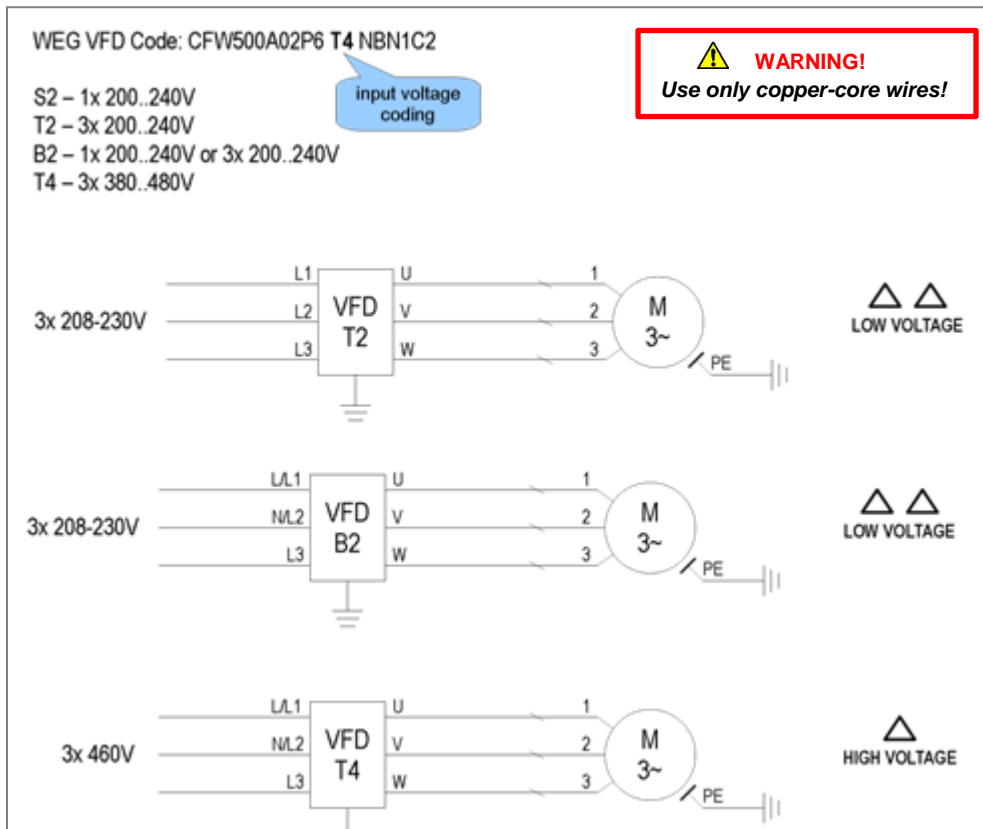

Fig. 46 Connection of 3ph frequency converters.

Connection the mains supply with control box (115V)

WARNING!
 Proper Field Wiring and Grounding Required!

All field wiring **MUST** be performed by qualified personnel. Improperly installed and grounded field wiring poses **FIRE** and **ELECTROCUTION** hazards. To avoid these hazards, you **MUST** follow requirements for field wiring installation and grounding as described in **NEC** and your local/state electrical codes. Failure to follow code could result in death or serious injury

WARNING!

Before starting connecting power supply, check conformity of the voltage and frequency of a supply network with the data shown on the device's rating plate. Permissible fluctuation of the supply voltage and its frequency to the values shown on the rating plate is $\pm 5\%$. If discrepancy exists, the device cannot be connected.

WARNING!
 Correct Phase Critical!

Correct phase sequence is critical. If phase sequence of the incoming line voltage is not correct, it could cause motor damage

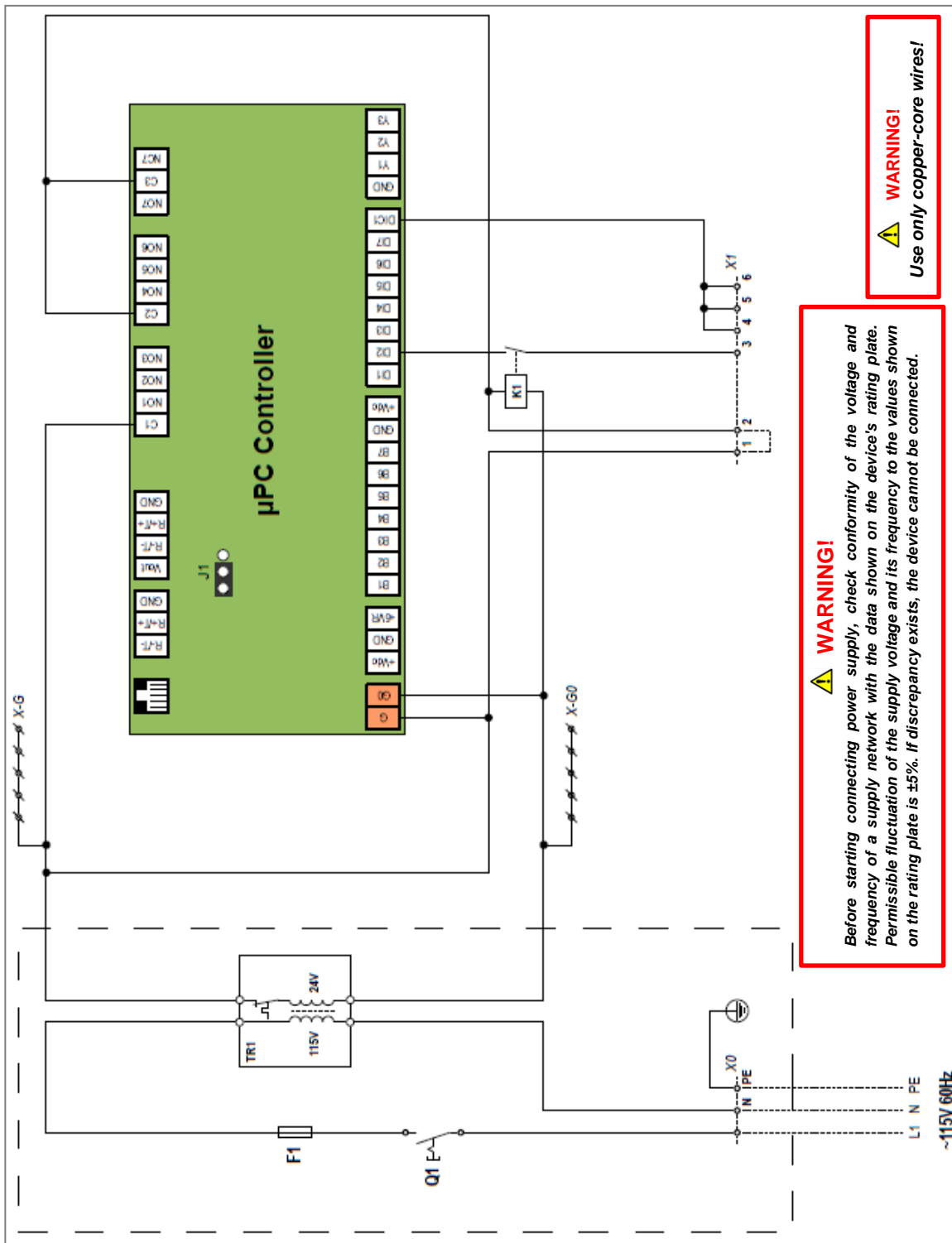

Fig. 47 Connection of the mains supply with control box (115V)

15.2 Connection of the mains supply with electric heater

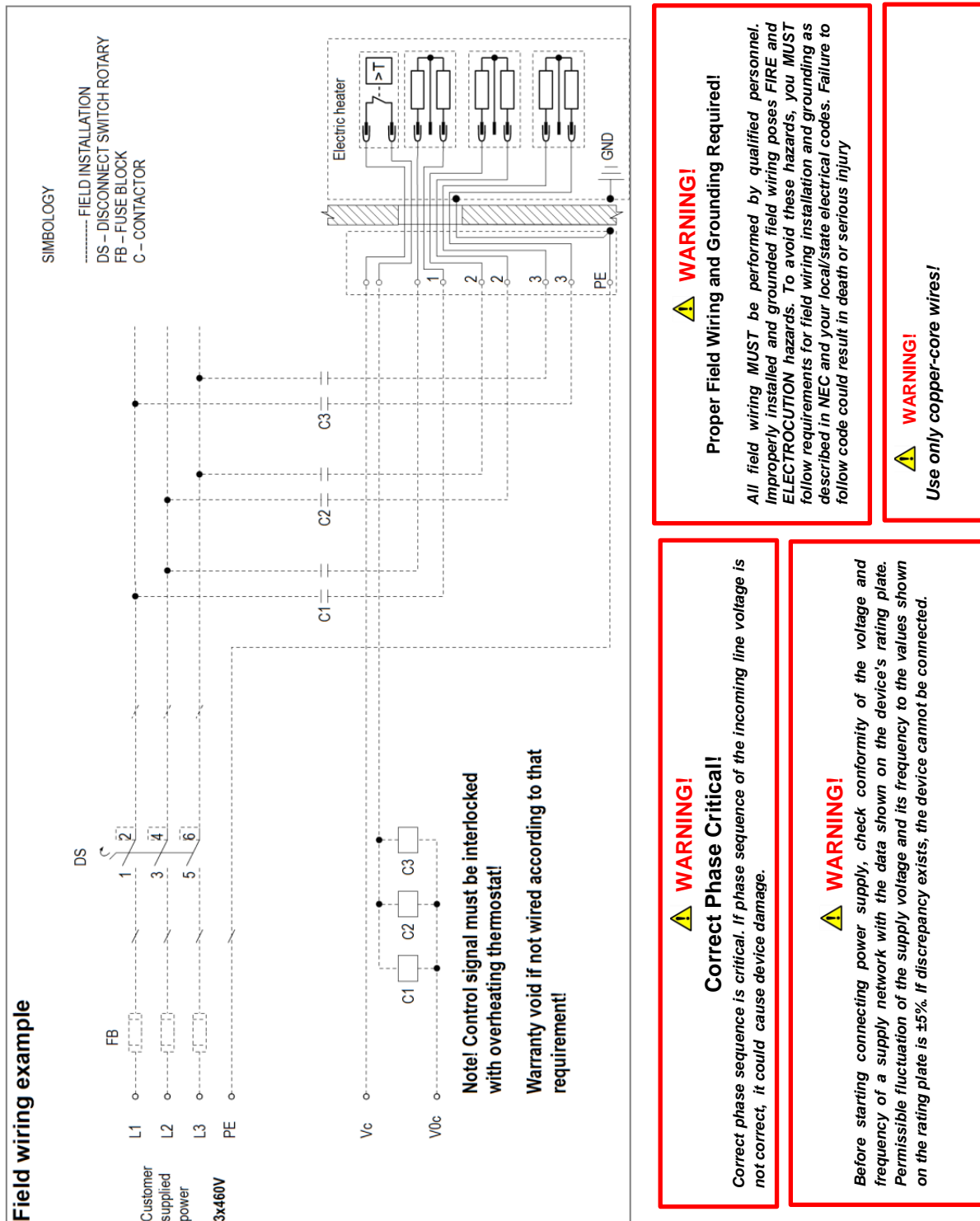

Fig. 48 An example for connection of the mains supply with electric heater

For other configuration see the **Attachment 1 OMM_AHU_VTS_USA_ATT.1_EH_WIRING**

16 Controls Diagrams

- ☑ **NOTICE!** Control circuits are incomplete and intended to be completed at time of installation. All field installed control circuit wiring shall be Class 1, as defined by Rule 16-004 of CSA C22.1 and Article 725-21 of ANSI/NFPA No. 70.

The Control Box is intended for field installation. An example of control system wiring is shown below.

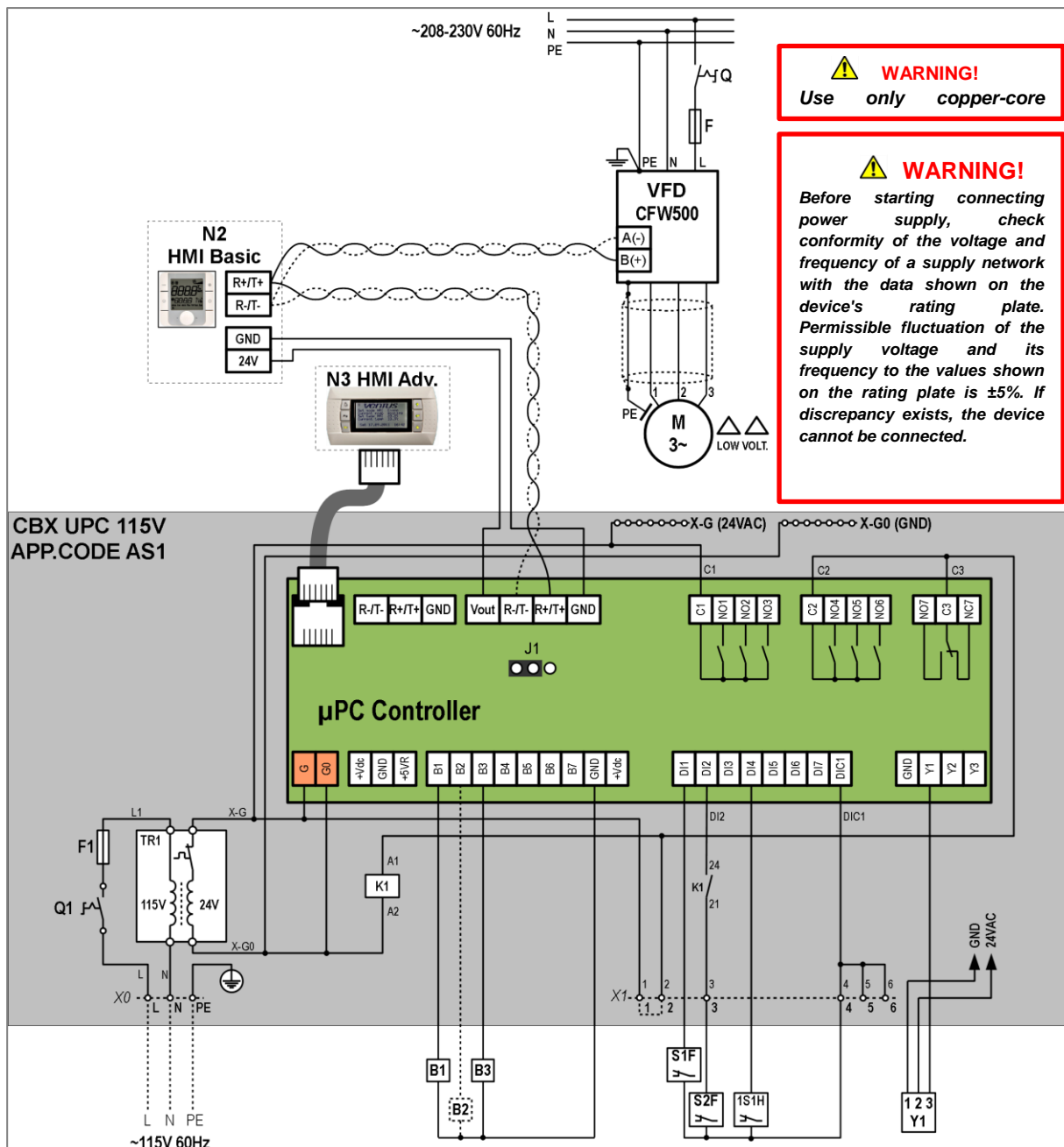

WARNING! Proper Field Wiring and Grounding Required!

All field wiring **MUST** be performed by qualified personnel. Improperly installed and grounded field wiring poses **FIRE** and **ELECTROCUTION** hazards. To avoid these hazards, you **MUST** follow requirements for field wiring installation and grounding as described in **NEC** and your local/state electrical codes. Failure to follow code could result in death or serious injury

16.1 Application AS-1

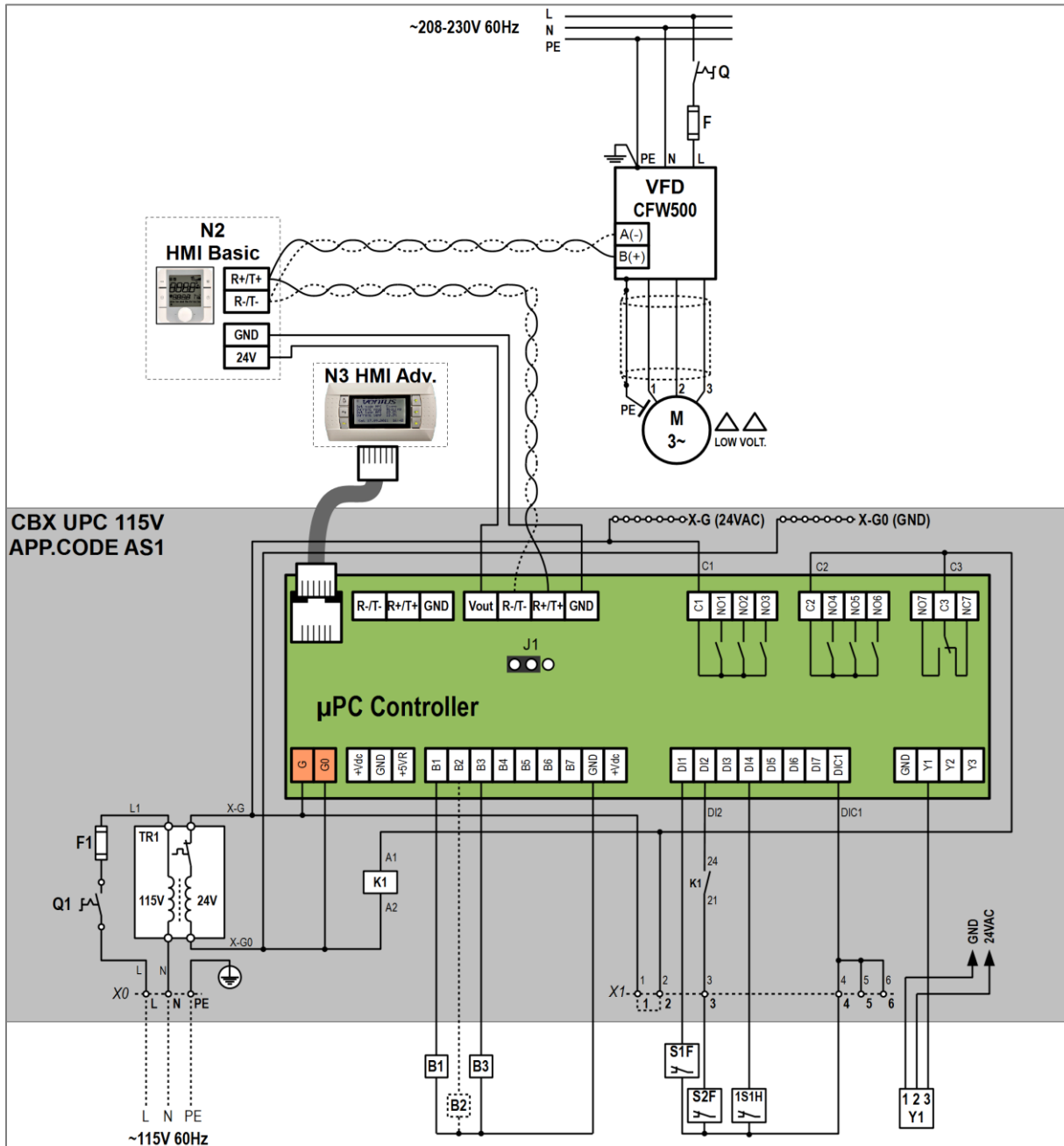

⚠ WARNING! Proper Field Wiring and Grounding Required!

All field wiring **MUST** be performed by qualified personnel. Improperly installed and grounded field wiring poses **FIRE** and **ELECTROCUTION** hazards. To avoid these hazards, you **MUST** follow requirements for field wiring installation and grounding as described in **NEC** and your local/state electrical codes. Failure to follow code could result in death or serious injury

⚠ WARNING! RISK OF ELECTRIC SHOCK. CAN CAUSE INJURY OR DEATH - DISCONNECT ALL REMOTE ELECTRIC POWER SUPPLIES BEFORE SERVICING

⚠ AVERTISSEMENT. RISQUE DE CHOCS ÉLECTRIQUES. PEUT CAUSER DES BLESSURES ET MÊME ENTRAÎNER LA MORT. COUPER LES SOURCES D'ALIMENTATION À DISTANCE AVANT LE DÉPANNAGE

⚠ WARNING! USE COPPER SUPPLY WIRES

⚠ AVERTISSEMENT. UTILISER DES FILS D'ALIMENTATION EN CUIVRE.

16.2 Application AS-4

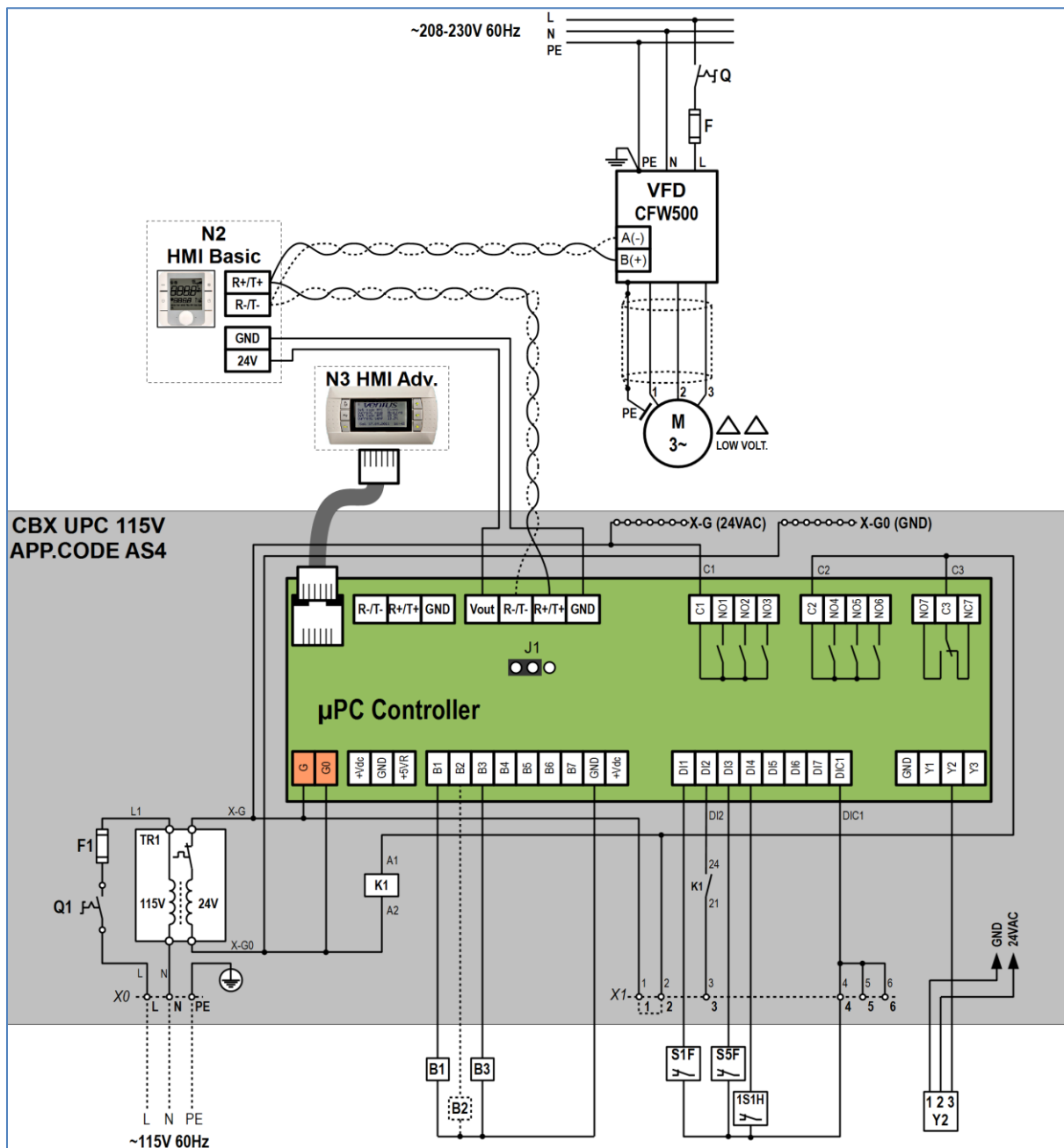

⚠ WARNING! Proper Field Wiring and Grounding Required!

All field wiring **MUST** be performed by qualified personnel. Improperly installed and grounded field wiring poses **FIRE** and **ELECTROCUTION** hazards. To avoid these hazards, you **MUST** follow requirements for field wiring installation and grounding as described in **NEC** and your local/state electrical codes. Failure to follow code could result in death or serious injury

⚠ WARNING! RISK OF ELECTRIC SHOCK. CAN CAUSE INJURY OR DEATH - DISCONNECT ALL REMOTE ELECTRIC POWER SUPPLIES BEFORE SERVICING

⚠ AVERTISSEMENT. RISQUE DE CHOCS ÉLECTRIQUES. PEUT CAUSER DES BLESSURES ET MÊME ENTRAÎNER LA MORT. COUPER LES SOURCES D'ALIMENTATION À DISTANCE AVANT LE DÉPANNAGE

⚠ WARNING! USE COPPER SUPPLY WIRES

⚠ AVERTISSEMENT. UTILISER DES FILS D'ALIMENTATION EN CUIVRE.

16.3 Application AS-5

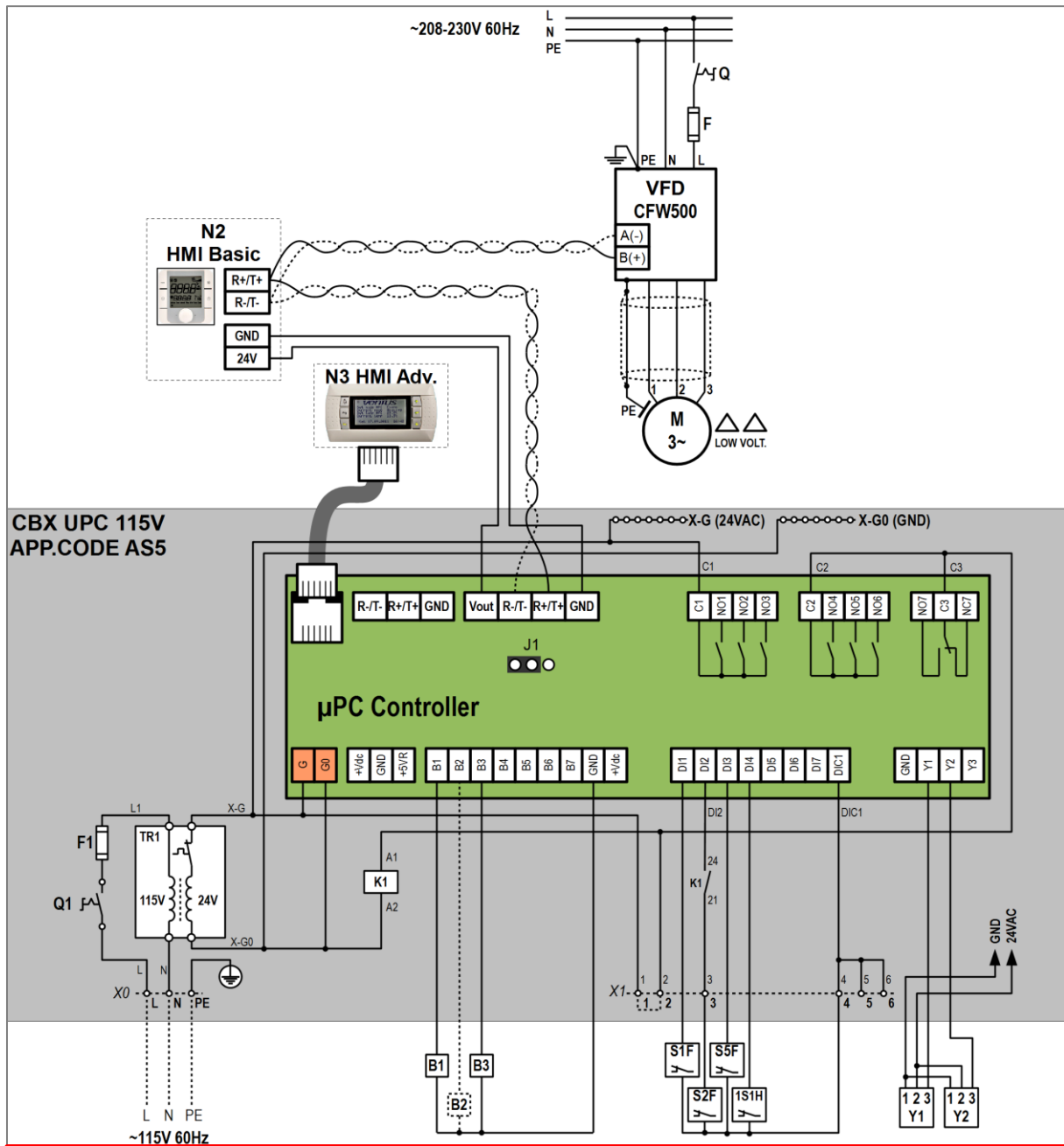

⚠ WARNING! Proper Field Wiring and Grounding Required!

All field wiring **MUST** be performed by qualified personnel. Improperly installed and grounded field wiring poses **FIRE** and **ELECTROCUTION** hazards. To avoid these hazards, you **MUST** follow requirements for field wiring installation and grounding as described in **NEC** and your local/state electrical codes. Failure to follow code could result in death or serious injury

⚠ WARNING! RISK OF ELECTRIC SHOCK. CAN CAUSE INJURY OR DEATH - DISCONNECT ALL REMOTE ELECTRIC POWER SUPPLIES BEFORE SERVICING

⚠ AVERTISSEMENT. RISQUE DE CHOCS ÉLECTRIQUES. PEUT CAUSER DES BLESSURES ET MÊME ENTRAÎNER LA MORT. COUPER LES SOURCES D'ALIMENTATION À DISTANCE AVANT LE DÉPANNAGE

⚠ WARNING! USE COPPER SUPPLY WIRES

⚠ AVERTISSEMENT. UTILISER DES FILS D'ALIMENTATION EN CUIVRE.

16.4 Application AS-8

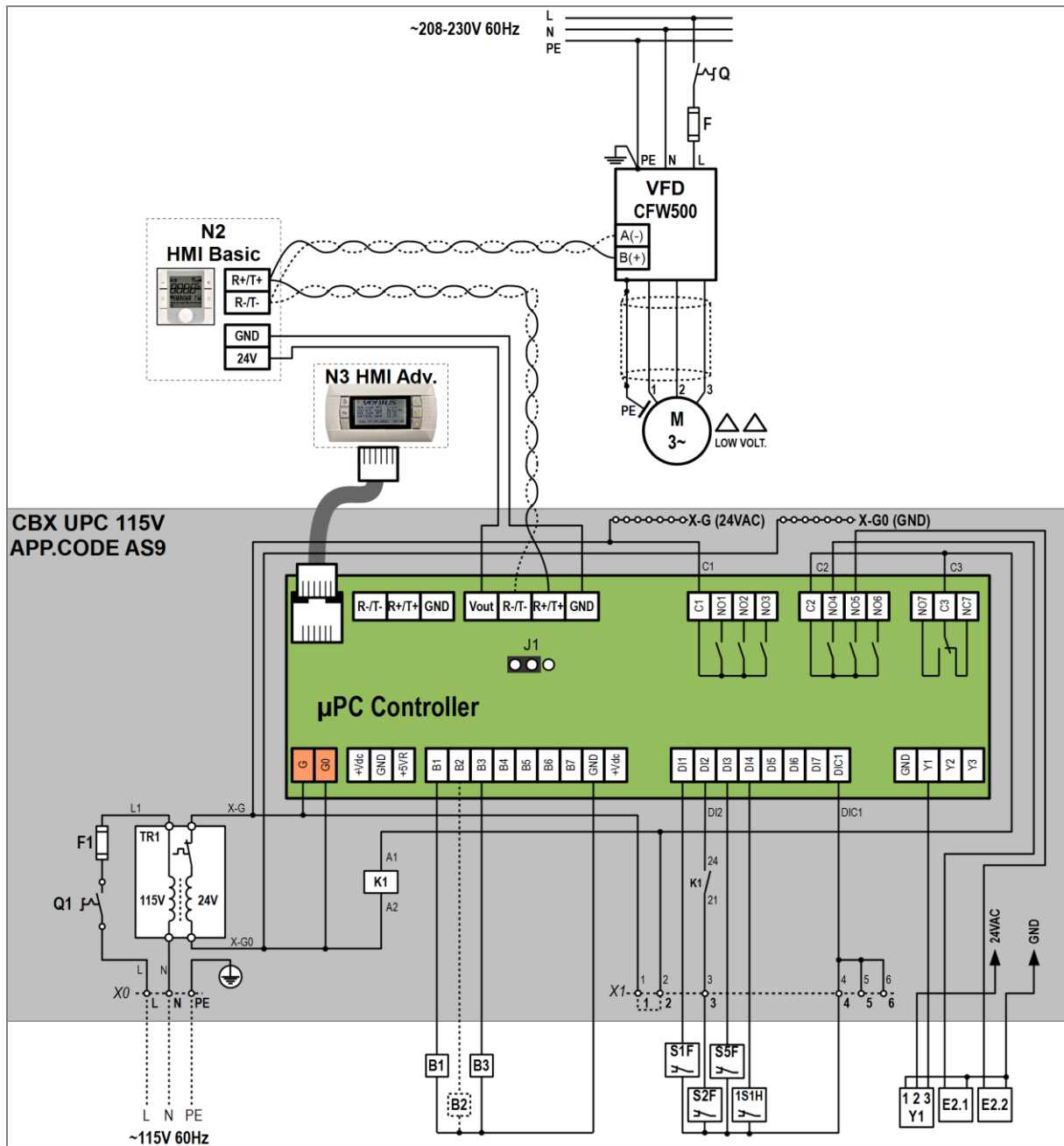

⚠ WARNING! Proper Field Wiring and Grounding Required!

All field wiring **MUST** be performed by qualified personnel. Improperly installed and grounded field wiring poses **FIRE** and **ELECTROCUTION** hazards. To avoid these hazards, you **MUST** follow requirements for field wiring installation and grounding as described in **NEC** and your local/state electrical codes. Failure to follow code could result in death or serious injury

⚠ WARNING! RISK OF ELECTRIC SHOCK. CAN CAUSE INJURY OR DEATH - DISCONNECT ALL REMOTE ELECTRIC POWER SUPPLIES BEFORE SERVICING

⚠ AVERTISSEMENT. RISQUE DE CHOCS ÉLECTRIQUES. PEUT CAUSER DES BLESSURES ET MÊME ENTRAÎNER LA MORT. COUPER LES SOURCES D'ALIMENTATION À DISTANCE AVANT LE DÉPANNAGE

⚠ WARNING! USE COPPER SUPPLY WIRES

⚠ AVERTISSEMENT. UTILISER DES FILS D'ALIMENTATION EN CUIVRE.

16.5 Applications AS 65-193

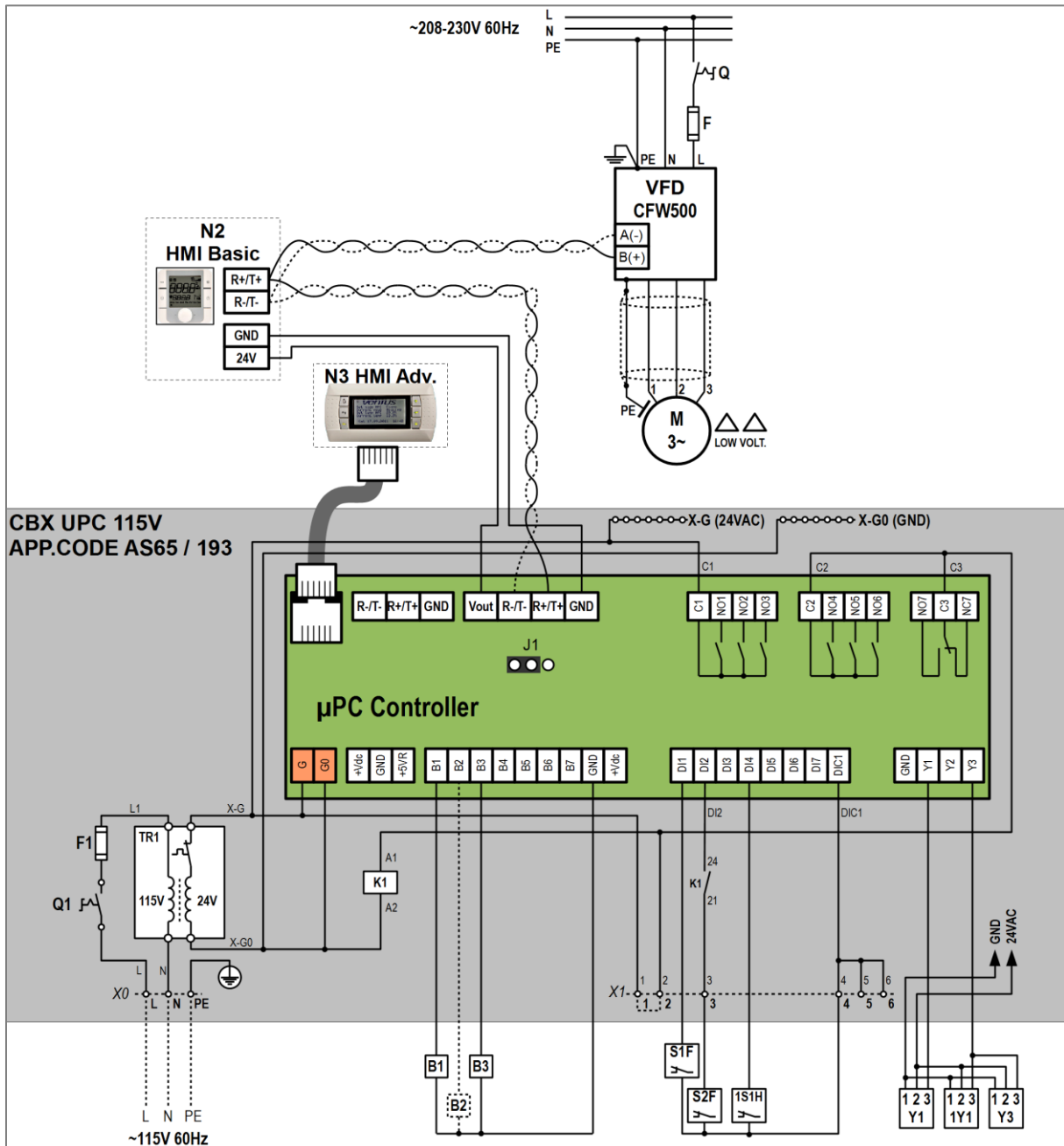

⚠ WARNING! Proper Field Wiring and Grounding Required!

All field wiring **MUST** be performed by qualified personnel. Improperly installed and grounded field wiring poses **FIRE** and **ELECTROCUTION** hazards. To avoid these hazards, you **MUST** follow requirements for field wiring installation and grounding as described in NEC and your local/state electrical codes. Failure to follow code could result in death or serious injury

⚠ WARNING! RISK OF ELECTRIC SHOCK. CAN CAUSE INJURY OR DEATH - DISCONNECT ALL REMOTE ELECTRIC POWER SUPPLIES BEFORE SERVICING

⚠ AVERTISSEMENT. RISQUE DE CHOCS ÉLECTRIQUES. PEUT CAUSER DES BLESSURES ET MÊME ENTRAÎNER LA MORT. COUPER LES SOURCES D'ALIMENTATION À DISTANCE AVANT LE DÉPANNAGE

⚠ WARNING! USE COPPER SUPPLY WIRES

⚠ AVERTISSEMENT. UTILISER DES FILS D'ALIMENTATION EN CUIVRE.

16.6 Applications AS 68-196

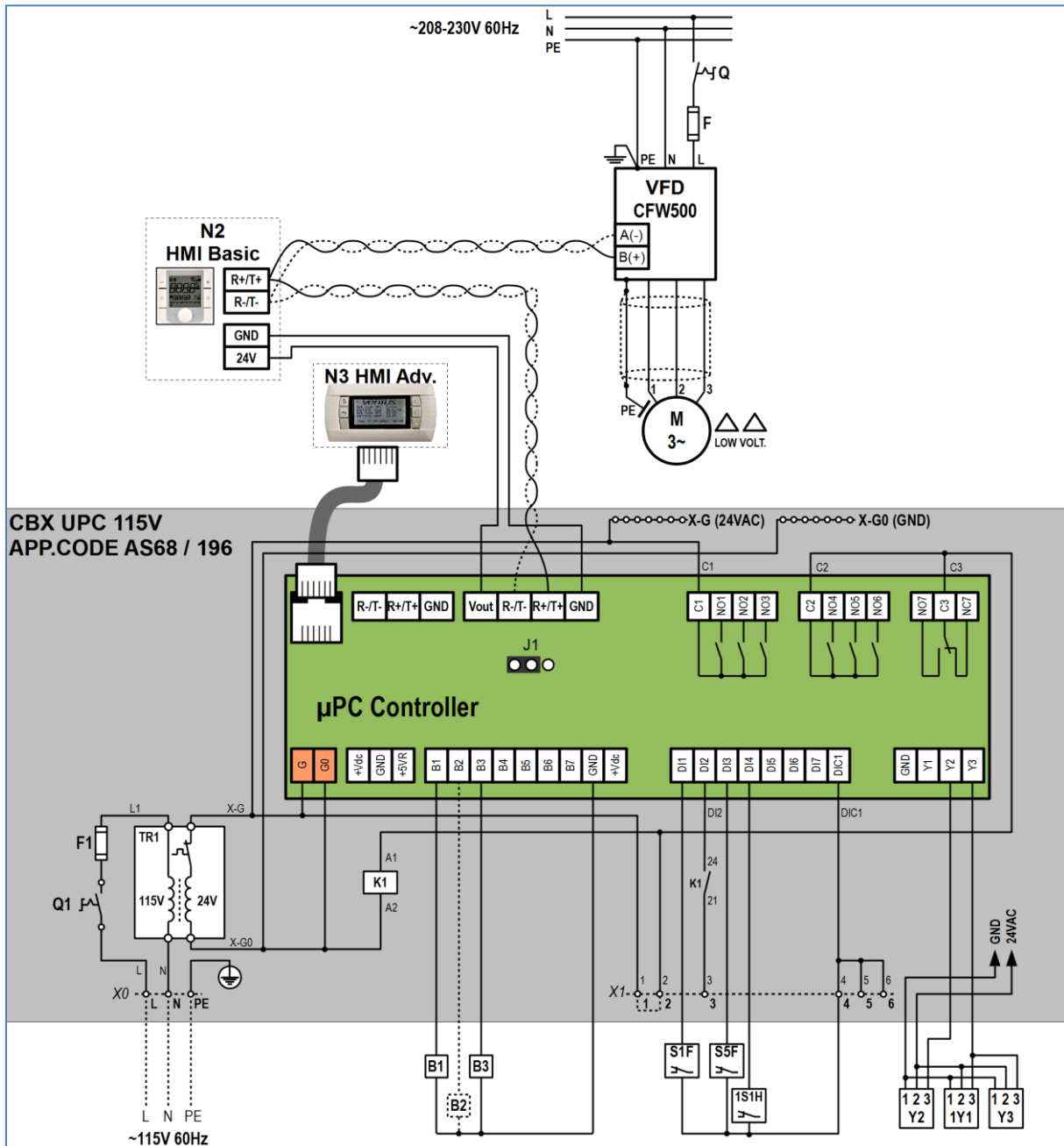

⚠ WARNING! Proper Field Wiring and Grounding Required!

All field wiring **MUST** be performed by qualified personnel. Improperly installed and grounded field wiring poses **FIRE** and **ELECTROCUTION** hazards. To avoid these hazards, you **MUST** follow requirements for field wiring installation and grounding as described in **NEC** and your local/state electrical codes. Failure to follow code could result in death or serious injury

⚠ WARNING! RISK OF ELECTRIC SHOCK. CAN CAUSE INJURY OR DEATH - DISCONNECT ALL REMOTE ELECTRIC POWER SUPPLIES BEFORE SERVICING

⚠ AVERTISSEMENT. RISQUE DE CHOCS ÉLECTRIQUES. PEUT CAUSER DES BLESSURES ET MÊME ENTRAÎNER LA MORT. COUPER LES SOURCES D'ALIMENTATION À DISTANCE AVANT LE DÉPANNAGE

⚠ WARNING! USE COPPER SUPPLY WIRES

⚠ AVERTISSEMENT. UTILISER DES FILS D'ALIMENTATION EN CUIVRE.

16.7 Applications AS 69-197

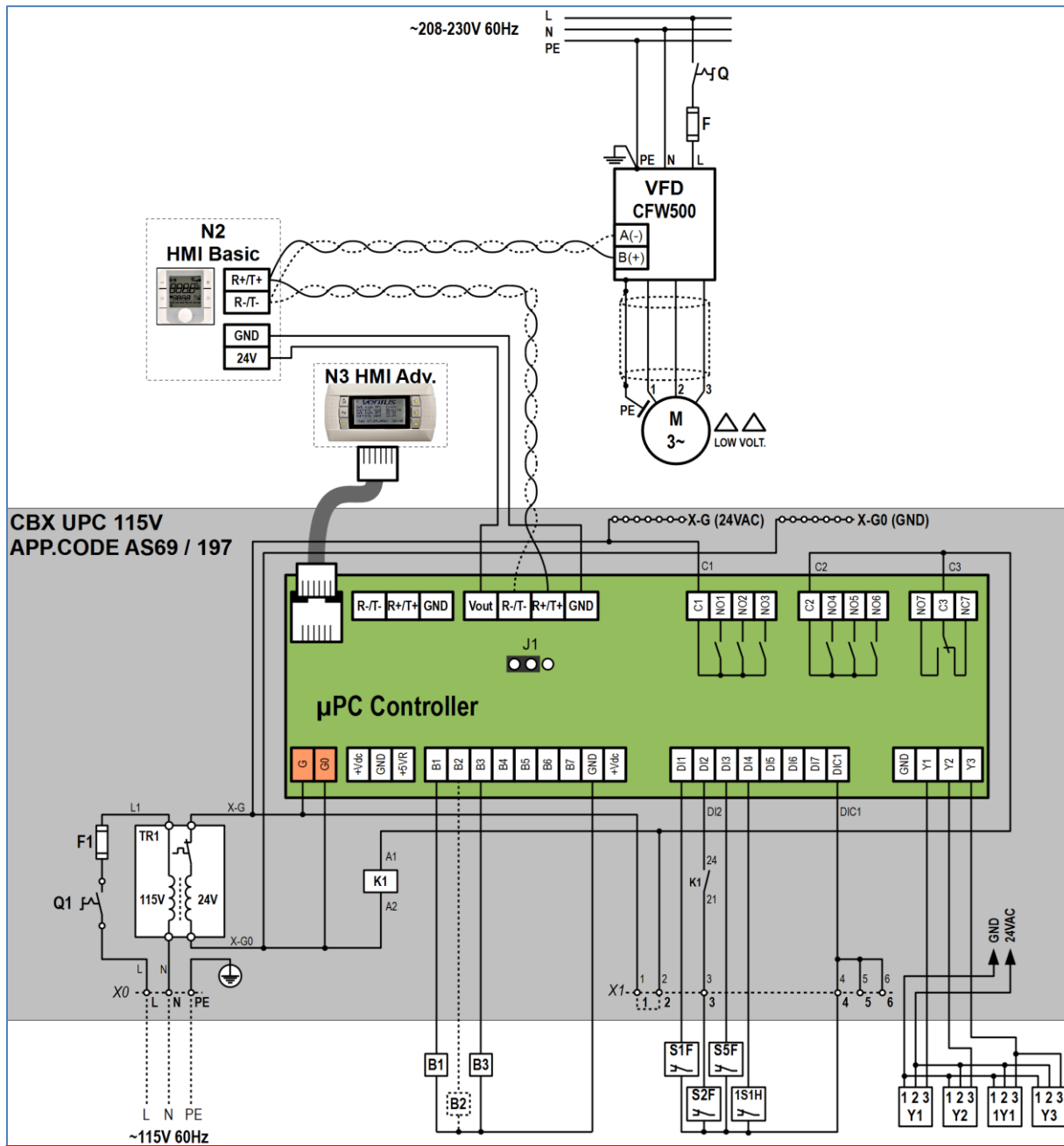

⚠ WARNING! Proper Field Wiring and Grounding Required!

All field wiring **MUST** be performed by qualified personnel. Improperly installed and grounded field wiring poses **FIRE** and **ELECTROCUTION** hazards. To avoid these hazards, you **MUST** follow requirements for field wiring installation and grounding as described in NEC and your local/state electrical codes. Failure to follow code could result in death or serious injury

⚠ WARNING! RISK OF ELECTRIC SHOCK. CAN CAUSE INJURY OR DEATH - DISCONNECT ALL REMOTE ELECTRIC POWER SUPPLIES BEFORE SERVICING

⚠ AVERTISSEMENT. RISQUE DE CHOCS ÉLECTRIQUES. PEUT CAUSER DES BLESSURES ET MÊME ENTRAÎNER LA MORT. COUPER LES SOURCES D'ALIMENTATION À DISTANCE AVANT LE DÉPANNAGE

⚠ WARNING! USE COPPER SUPPLY WIRES

⚠ AVERTISSEMENT. UTILISER DES FILS D'ALIMENTATION EN CUIVRE.

16.8 Applications AS 72-200

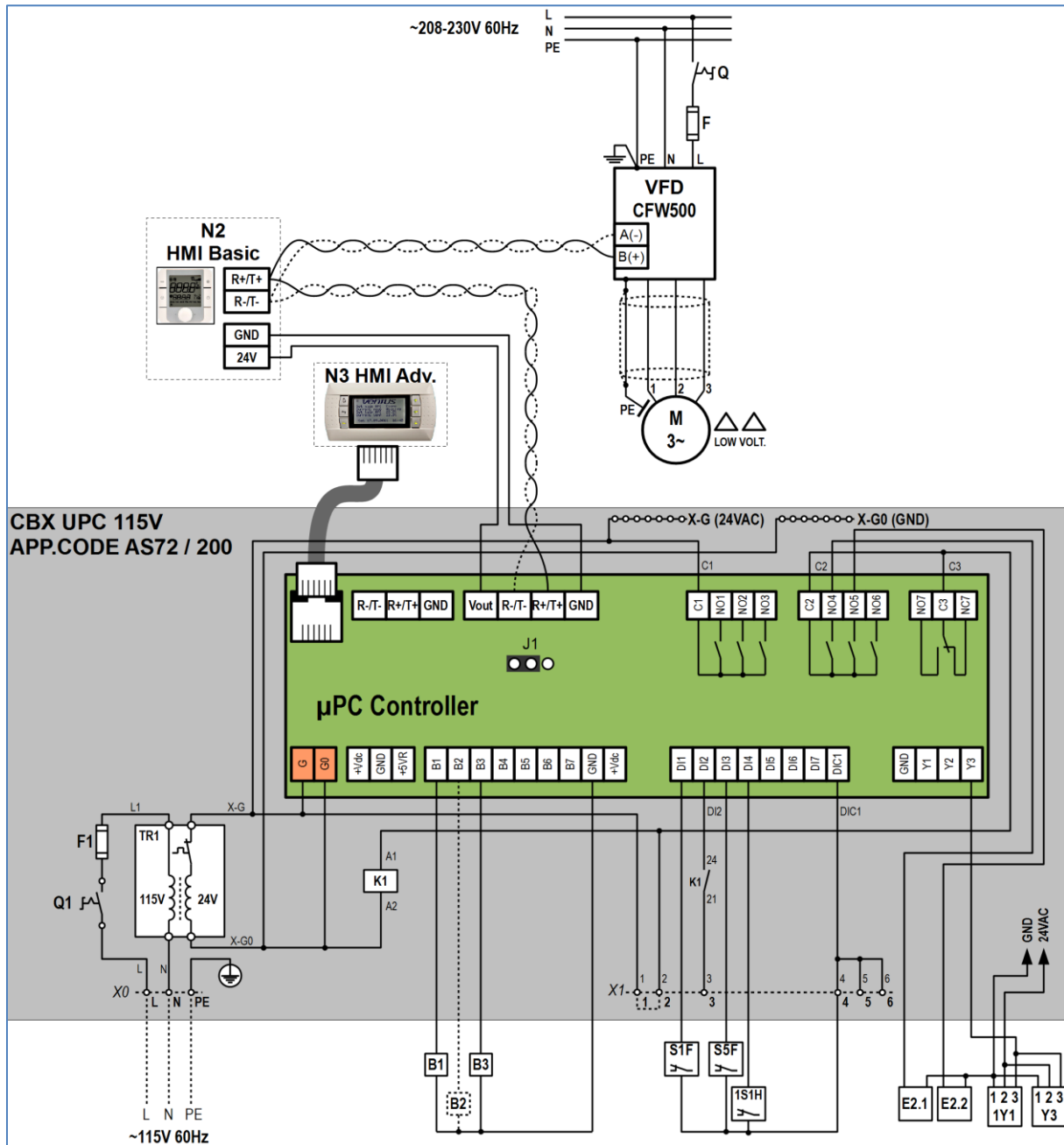

⚠ WARNING! Proper Field Wiring and Grounding Required!

All field wiring **MUST** be performed by qualified personnel. Improperly installed and grounded field wiring poses **FIRE** and **ELECTROCUTION** hazards. To avoid these hazards, you **MUST** follow requirements for field wiring installation and grounding as described in **NEC** and your local/state electrical codes. Failure to follow code could result in death or serious injury

⚠ WARNING! RISK OF ELECTRIC SHOCK. CAN CAUSE INJURY OR DEATH - DISCONNECT ALL REMOTE ELECTRIC POWER SUPPLIES BEFORE SERVICING

⚠ AVERTISSEMENT. RISQUE DE CHOCS ÉLECTRIQUES. PEUT CAUSER DES BLESSURES ET MÊME ENTRAÎNER LA MORT. COUPER LES SOURCES D'ALIMENTATION À DISTANCE AVANT LE DÉPANNAGE

⚠ WARNING! USE COPPER SUPPLY WIRES

⚠ AVERTISSEMENT. UTILISER DES FILS D'ALIMENTATION EN CUIVRE.

16.9 Applications AS 73-201

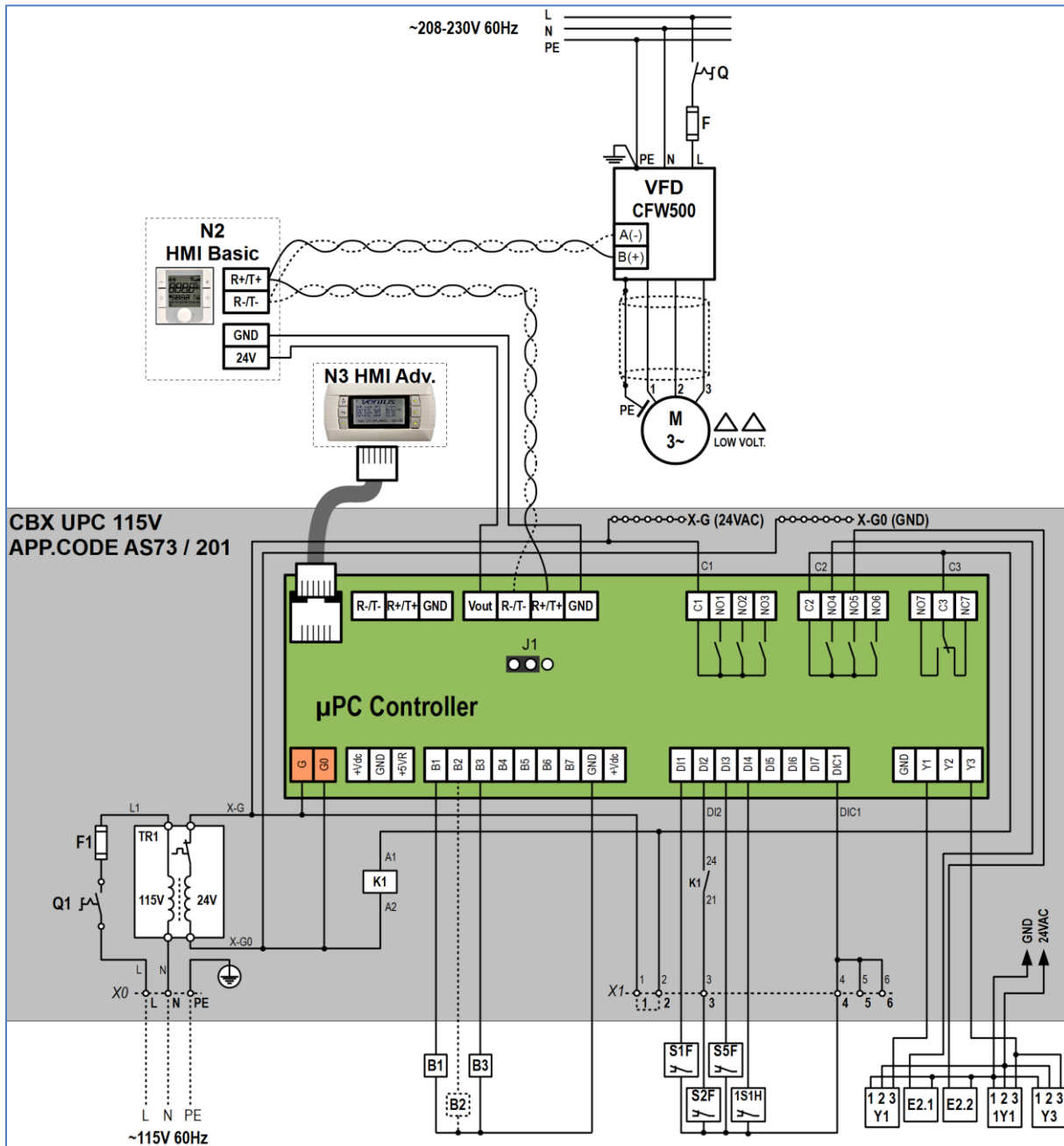

⚠ WARNING! Proper Field Wiring and Grounding Required!

All field wiring **MUST** be performed by qualified personnel. Improperly installed and grounded field wiring poses **FIRE** and **ELECTROCUTION** hazards. To avoid these hazards, you **MUST** follow requirements for field wiring installation and grounding as described in **NEC** and your local/state electrical codes. Failure to follow code could result in death or serious injury

- ⚠ WARNING! RISK OF ELECTRIC SHOCK. CAN CAUSE INJURY OR DEATH - DISCONNECT ALL REMOTE ELECTRIC POWER SUPPLIES BEFORE SERVICING**
- ⚠ AVERTISSEMENT. RISQUE DE CHOCS ÉLECTRIQUES. PEUT CAUSER DES BLESSURES ET MÊME ENTRAÎNER LA MORT. COUPER LES SOURCES D'ALIMENTATION À DISTANCE AVANT LE DÉPANNAGE**

- ⚠ WARNING! USE COPPER SUPPLY WIRES**

- ⚠ AVERTISSEMENT. UTILISER DES FILS D'ALIMENTATION EN CUIVRE.**

17 AHU's Technical Data Sheet

Detailed data of the air handling units their maximum and minimum and designed operation parameters are available in computing software, that is available on www.vtsgroup.com.

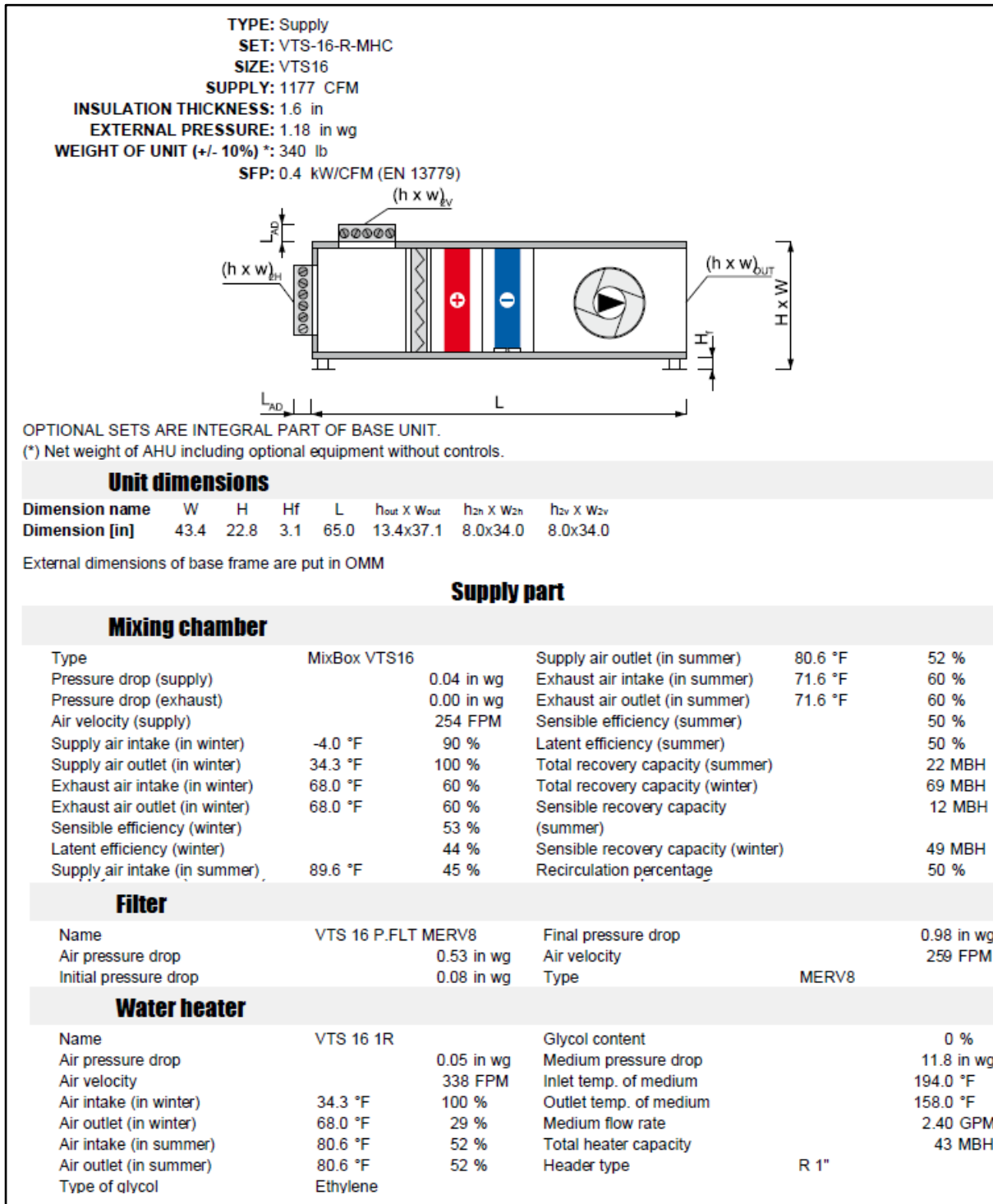

Fig. 49 An example of computing technical data



Water cooler									
Name	VTS 16 4R			Medium pressure drop					5.2 in wg
Air pressure drop		0.24 in wg		Inlet temp. of medium					42.8 °F
Air velocity		348 FPM		Outlet temp. of medium					53.6 °F
Air intake (in winter)	68.0 °F	29 %		Medium flow rate					3.03 GPM
Air outlet (in winter)	68.0 °F	29 %		Total cooler capacity					16 MBH
Air intake (in summer)	80.6 °F	52 %		Sensible capacity					12 MBH
Air outlet (in summer)	71.6 °F	65 %		Header type		R 1"			
Type of glycol	Ethylene			Designed for wet conditions					
Glycol content		0 %							
Fan section									
Fan				Rated voltage					3x460 V
Name	VTS 16 IMPLLR.ASM			Rated current					1.5 A
	VS-315/0,875			Rated power					1.0 HP
Static pressure		2.05 in wg		Electric power consumption					0.5 kW
Dynamic pressure		0.09 in wg		Electric power consumption (Clean					0.4 kW
External pressure		1.18 in wg		F.)					
Static efficiency		71 %		Rated revolutions					1765 rpm
Total efficiency		74 %		Frequency converter's power					3x460 V
Rated revolutions		2115 rpm		supply					
Shaft power		0.5 HP		Frequency converter's output power					3x460 V
Motor	EL.MTR 143T-1HP/4p			supply					
	OPSB 208-230/460V			Frequency					72 Hz
IEC size				Circuit breaker					3.0 A
Frequency		72 Hz		SFPs					0.4 kW/CFM
Sound-level table									
Frequency		125 Hz	250 Hz	500 Hz	1000 Hz	2000 Hz	4000 Hz	8000 Hz	Lw dB(A)
Intake	dB(A)	45	58.5	64.5	62.8	59.2	49.9	41.4	68.1
Outlet	dB(A)	50.6	64.1	70.1	70.3	68.5	63.8	58.1	75.3
Environment	dB(A)	40.6	50.7	50.4	48.5	48.9	34.8	26.1	55.9
Sound press. **	dB(A)	33.6	43.7	43.4	41.5	41.9	27.8	19.1	48.9

Fig. 50 (cont.) An example of computing technical data

VTS reserves the right to implement changes without prior notice.

VTS America Inc.
 1650 Horizon Parkway NE, Suite 100
 Buford, GA, 30518, U.S.A.
 +1-470-809-6811