



VENTUS S-Type Air-Handling Units

Operation and Maintenance Manual



ATTENTION:

In order to ensure proper condensate elimination, this Air Handling Unit requires accurate levelling. Use a spirit level tool when installing.

Manufactured in accordance with EN 1886, EN 13053

VTS reserves the right to implement changes without prior notice

Table of Contents

1. INTRODUCTION	4
2. APPLICATION AND DESIGN.....	4
3. TRANSPORT AND STORAGE.....	6
4. MOUNTING, CONNECTION TO UNIT-RELATED SYSTEMS	7
4.1. Suspending the VENTUS S-Type unit.	7
4.2. Connecting the ventilation ducts.....	9
4.3. Connection of coolers.....	10
4.4. Draining out condensate.....	11
4.5. Electric connection.....	12
4.6. Fan sets.....	12
4.7. Automatic control.....	15
5. PREPARATION FOR START-UP.....	16
5.1. Electrical system.....	16
5.2. Filters.....	16
5.3. Fan unit.....	16
6. START-UP AND ADJUSTMENT	17
6.1. Measurement of the air quantity and AHU output adjustment.	17
7. OPERATION AND MAINTENANCE	18
7.1. Dampers.....	19
7.2. Filters.....	19
7.3. Cooler.....	20
7.4. Fan unit.....	20
7.5. Test measurements.....	20
8. SAFETY INSTRUCTIONS	20
9. INFORMATION	21

1. INTRODUCTION

In-depth familiarization with the content of this manual, assembly and operation of the air-handling unit in line with the instructions provided and obeying all safety regulations constitute the basis of an efficient, safe and non-failure operation of the device.

Works related to unloading packages with AHU subassemblies, transportation of the packages, AHU blocks and elements, connecting AHU-related systems as well as maintenance and repair have to be carried out by qualified specialists or have to be supervised by the authorized personnel.

The **qualified technical personnel** is understood as the trained specialists, who have been authorized to perform necessary operations and are able to troubleshoot all potential problems on the basis of their professional experience, knowledge of the subject-related standards, documentation and operational regulations and safety procedures.

This operation and maintenance manual does not cover all possible variants of the units configurations, examples of their assembly and installation as well as start-up, operating, repairing and maintenance. If the units are used in the way they were intended to, this documentation and any other materials provided with the unit contain information designed for the qualified technical personnel.



Connection of the AHU to related systems, start-up, operation and maintenance of the device have to comply with the directives and law regulations in force in the country where the unit is installed.



AHU SVS 35-100 guarantee repairs can be carried out only by a VTS Service Providers having the appropriate certificates. It is recommended to rely on VTS Authorized Service Providers in such matters as the installation, start-up, maintenance and repairs of the AHU units.



This manual should always be kept handy for reference and be easily available for the servicing personnel.

2. APPLICATION AND DESIGN

The series of SVS provides 5 sizes of a unit. The product line is designed for air handling processes in range of capacity from 1800 m³/h to 10400 m³/h. The AHUs SVS 35-100 are manufactured as suspended units and assigned for installation inside of building. The SVS air-handling units are designed for a ventilation system where the rotating parts of the unit (a fan's rotor) are accessible neither from the overpressure nor underpressure side of the unit. The ventilation system is understood as a net of ventilating ducts.

The SVS AHUs have the following functions: 1- filtration (panel filters), 2- cooling (water cooler 4 and 6 rows, DX cooler 3 and 4 rows), 3-fan, available with AC and EC motors, 4 – air damper, 5 – outlet flexible connection, fig.1.

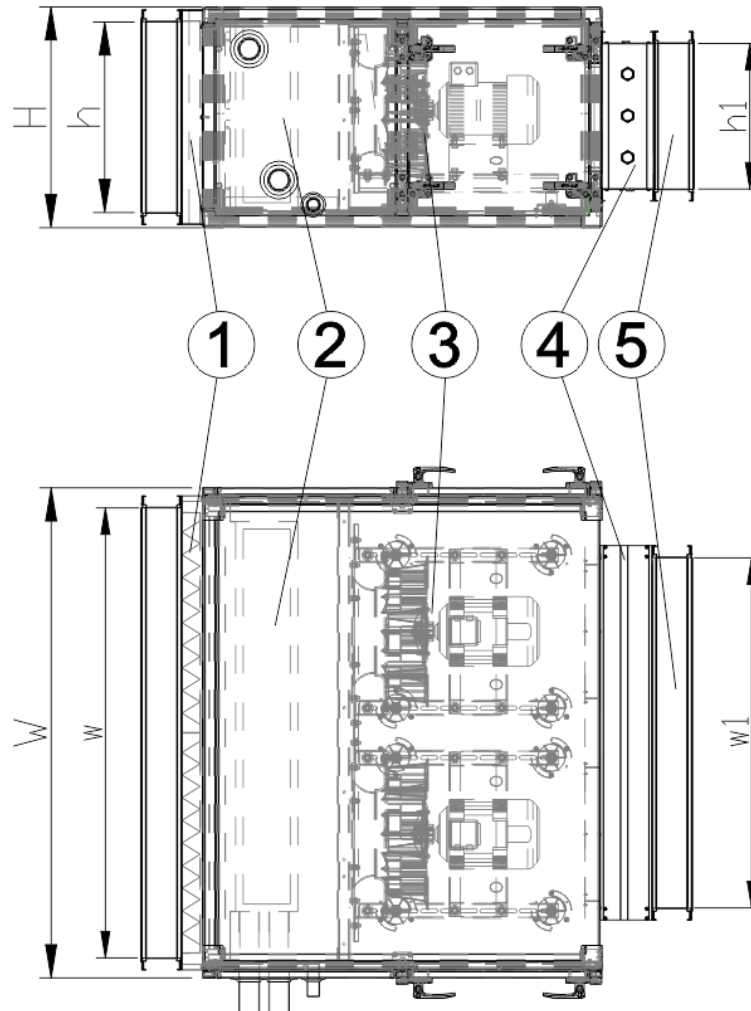

Fig.1. Example of suspended AHUs type SVS 35-100

Tab.1 Dimensions of AHUs type SVS 35-100

AHU type	AHU external sizes [mm]			AHU mass [kg]		Air damper size [mm]	Flexible connection size [mm]	
	Length	Wide	Height	4R coil	6R coil	-	inlet (w x h)	outlet (w1 x h1)
SVS-35	1 120	1 160	530	98	106	342 x 264	1100 x 470	342 x 264
SVS-50	1 120	1 300	595	114	124	365 x 275	1240 x 535	365 x 275
SVS-70	1 120	2 000	530	166	181	1294 x 264	1940 x 470	1294 x 264
SVS-85	1 120	2 000	655	187	205	1270 x 275	1940 x 595	1270 x 275
SVS-100	1 120	2 000	655	200	220	1425 x 275	2140 x 595	1425 x 275

This type of suspended AHUs is available only in the right-hand (RH) configuration (fig.2).

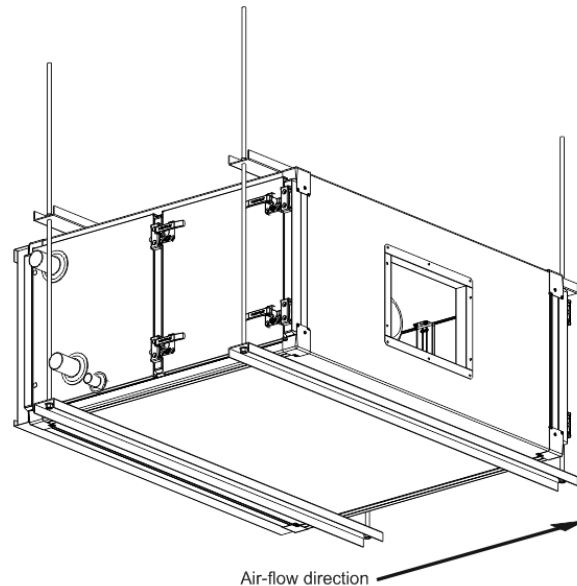

Fig. 2 Right-hand version of the VS 35-100 AHU

3. TRANSPORT AND STORAGE

- ☞ The SVS AHUs are delivered assembled
- ☞ After the AHUs, are delivered in closed, properly labeled and undamaged palettes and after signing the consignment note by the client representative, the units become a property of the customer.
- ☞ Right after the unit is delivered, check the condition of the package and examine if all necessary elements have been delivered, in conformity with the attached specification and consignment note.
- ☞ Unloading AHUs, and transporting them to the installation site should be carried out by the qualified personnel, with the use of special equipment.

Palettes should be unloaded and transported to the AHU's installation site using a fork lift (fig.3) or a crane (fig4).

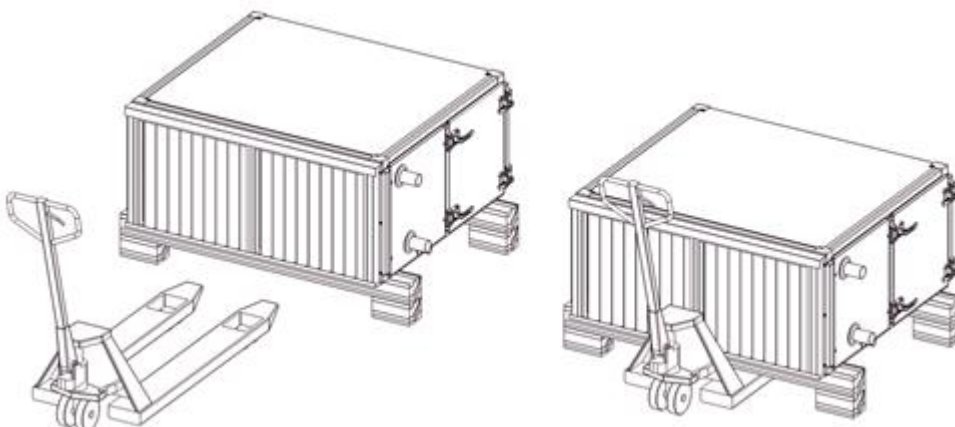

Fig.3. Using a forklift to transport the unit

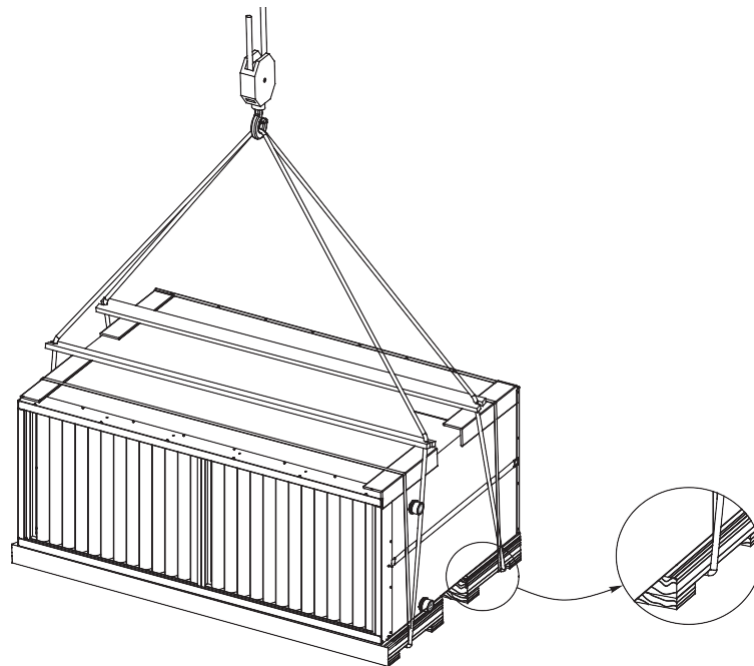

Fig. 4 Transport with the use of a crane

The units have to be transported in their working position (horizontally) and they should not be stored one on the other.

The units and their optional components should be stored in the following conditions:

- relative humidity in the room: $\varphi < 80 \%$ at t (temperature) = 20°C
- ambient temperature: $-40^{\circ}\text{C} < t < +60^{\circ}\text{C}$
- the devices should be out of the reach of any caustic dust, gas or steam or any other chemical substances which may have pro-corrosive influence on the unit and its components.

While storing the unit, its plastic packaging must be unsealed.



Any damages caused by the improper transportation, unloading or storage are not covered by the guarantee and any claims laid by way of the aforementioned issues will not be examined by VTS.

4. MOUNTING, CONNECTION TO UNIT-RELATED SYSTEMS



Connecting supplied SVS 35-100 units to the installation falls within the competence of the Client.



By default the SVS 35-100 AHU should be suspended in horizontal position.

4.1. Suspending the VENTUS S-Type unit.

Suspension of an AHU as a part of ventilation ducts is carried out using additional bars (out of VTS delivery) (fig.6). Application of the screwed rods facilitates and speeds up the suspension and leveling of AHU (the screwed rods are not included).



The AHU should be levelled according to the two axis double spirit level, fixed on the bottom of the unit near the syphon.

It is recommended to use vibro absorber to suspend the units to reduce the vibrations transmitted to the supporting structure.

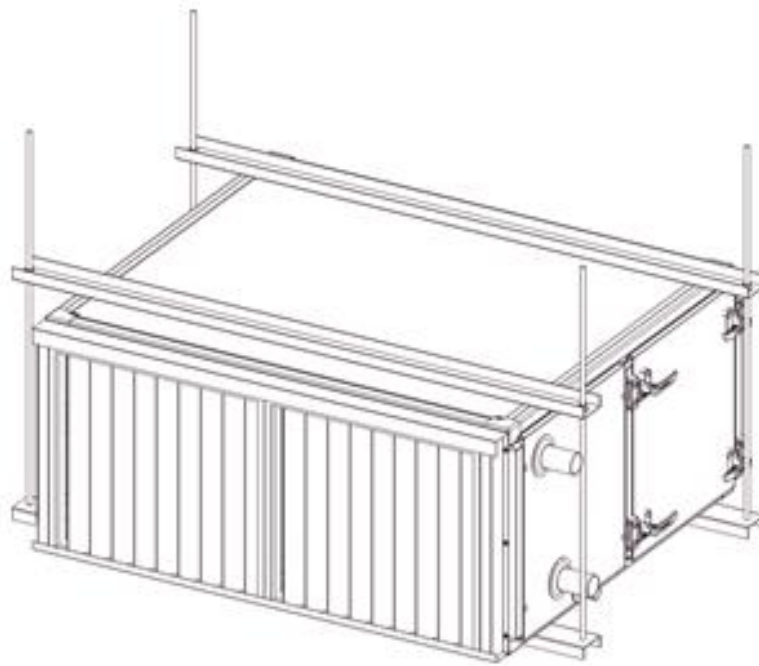

Fig.5. Example of suspending the AHU sections

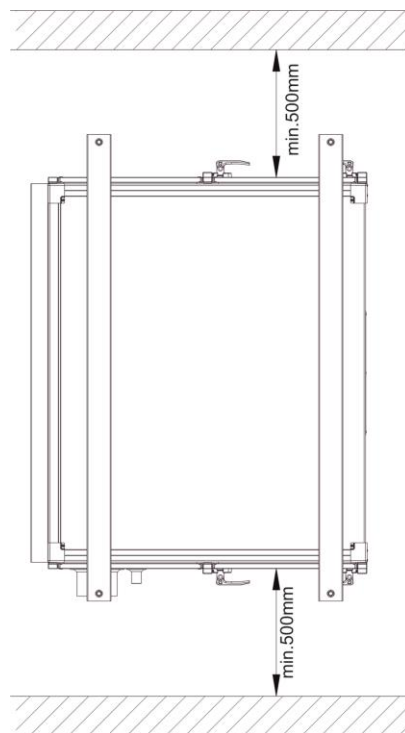

Fig.6. Suspension grips arrangement

The space between the slings must allow for the assembly of the siphon (if there are no the special pump) which drains the condensate out of the unit.



On both sides of the AHU at the service hole level should be free space min. 500mm to allow for a possible replacement the fan (fig.6).

VTS reserves the right to implement changes without prior notice

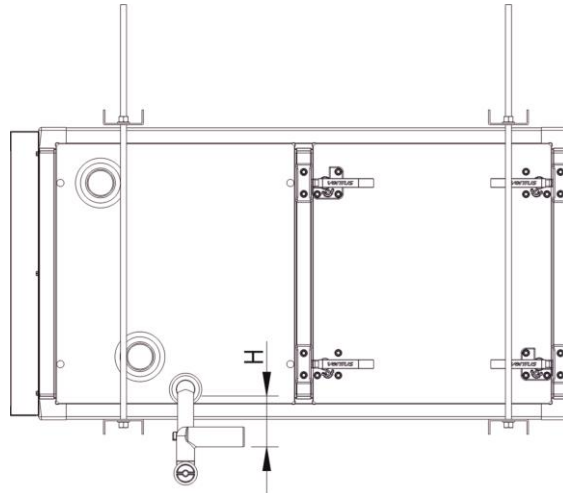

Fig.7. Examples of AHU

*H - see table 3

installation

4.2. Connecting the ventilation ducts



Attention: Before connecting the ducts, it is necessary to make an electric connection of motor fan, in order to ensure an appropriate direction of the fan rotation.

The ventilation ducts should be connected to the AHU with flexible connections (optional accessory) which suppress the vibrations of the unit and level the coaxial deflection of the duct and the AHU outlets. Flexible connections are equipped with flanges and sealing. The flexible flanges should be connect with ducts by drilling screws (Fig.8a) or additional clamping elements (Fig. 8b). Materials to connect ducts are not supplied as standard delivery.

The flexible connection should be stretched to about 110 mm.

The ducts connected to the AHU have to be suspended or underpinned with dedicated support elements.

Conducting the ducts with the fittings should be done in such a way so as to avoid eliminate possible increase of the noise level in the ventilation system.

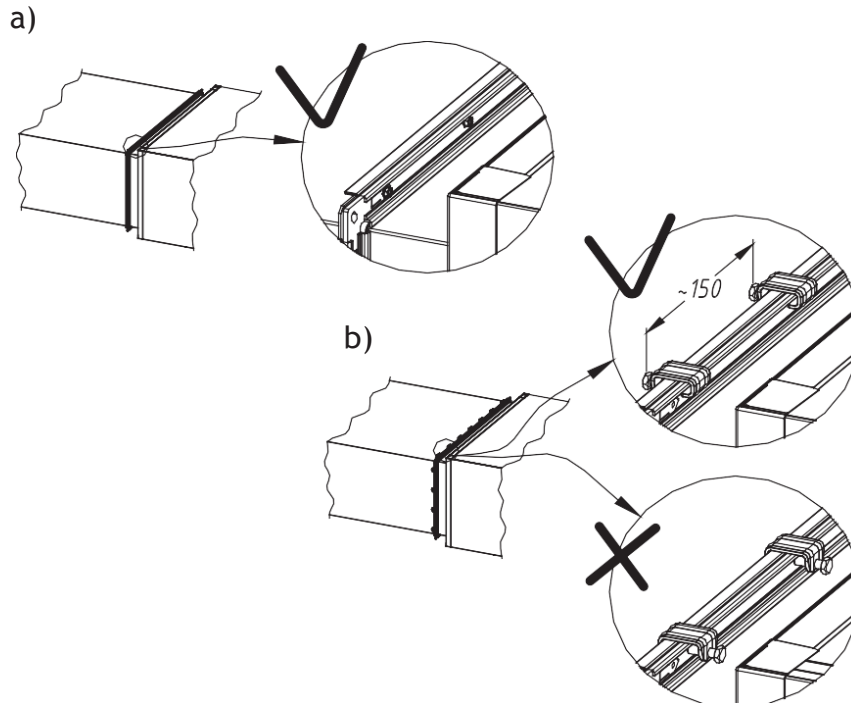

Fig.8. Duct's connection rules

4.3. Connection of coolers

Connection of coolers should be done in such a way so as not to allow for stresses exchanger's connections which may result in mechanical damages or leakages. The pipeline weight and thermal stresses cannot be passed onto the exchanger's connections. Depending on local conditions, please use the compensation at the inlet and outlet of the pipeline system, in order to level the pipeline's linear expansion. During assembly of the supply system to the cooler equipped with the screwed connections, counter the exchanger's connection with additional wrench (fig.9).

The supply system should be planned in such a way so that it does not collide with the other AHU sections. The way of connecting the exchangers with the supply system should allow for an easy pipeline disassembly in order to remove the exchanger from the AHU, during maintenance and service operations.

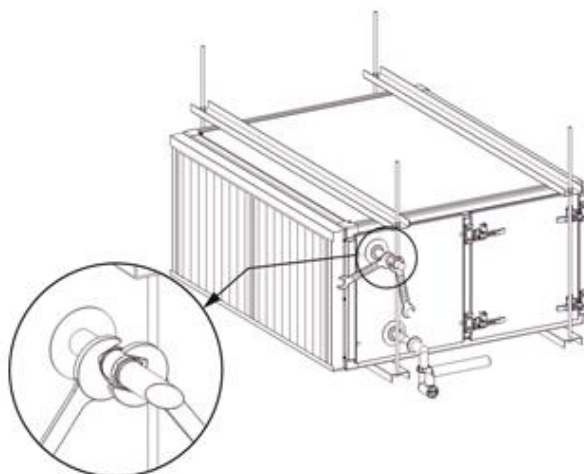

Fig.9. Securing the screwed connections of the exchanger

Table 2. Diameters of coolers connection pipes

AHU type	Rows number	Connection pipe diameter	Rows number	Inlet connection pipe diameter [mm]	Outlet connection pipe diameter [mm]
	Water cooler		DX cooler		
SVS-35	4R	DN32	6	2xØ16	2xØ28
	6R				
SVS-50	4R	DN50	6	2xØ22	2xØ35
	6R				
SVS-70	4R	DN50	6	2xØ22	2xØ35
	6R				
SVS-85	4R	DN50	6	2xØ22	2xØ35
	6R				
SVS-100	4R	DN50	6	2xØ22	2xØ42
	6R				

Inlet and outlet exchanger's connections should be connected so that the exchanger operates in a counter-current way. Streamwise operation results in the lower average discrepancy of temperatures, which influences the exchanger's performance.

Examples of connecting inlet and outlet pipelines for various AHU versions shown in the picture.

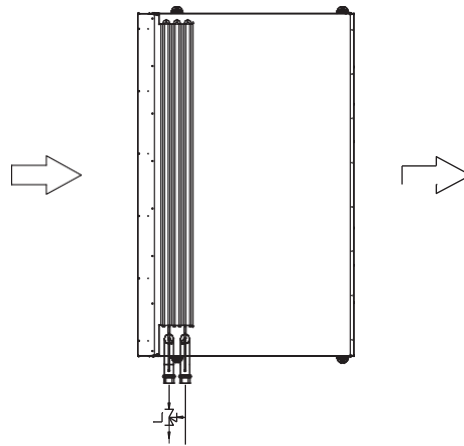

Fig.10. Example of a feeding water exchanger

4.4. Draining out condensate

The outlet condensate connections, led outside the AHU's casing are assembled in the drain plates of glycol, cross-flow and rotary exchangers (the diameter of drain pan connection pipe is 32mm).

Siphons, which are designed to drain out condensed water from the exchangers at different pressure of the section and environment, should be connected to the drain connections.

Drain siphons or siphon parts for SVS AHUs **are not supplied as a standard delivery.**

Siphon's usable „H" height depends on the pressure difference between the AHU section, where the condensate is drained during the operation and under the ambient pressure. „H" dimension is provided in mm and must be higher than the pressure difference expressed in mmH₂O.

Table 3. Siphons' operational height

No.	Total fan's pressure [Pa]	Size H [mm]
1.	< 600	60
2.	600-1000	100

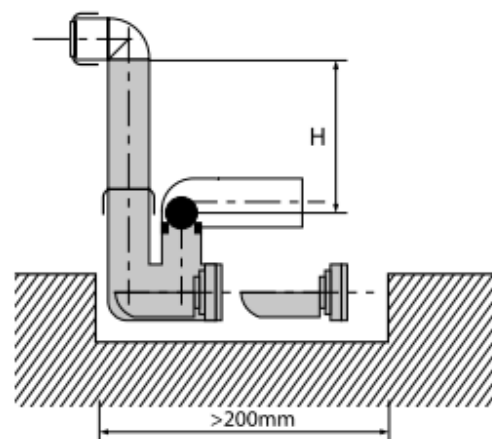

Fig.11. Ball siphon

It is allowable to join together siphons of various units with one drain interceptor provided that the interceptor is equipped with air-escape. Before starting the AHU, fill the siphon with water.

It is also possible to use a special type of mechanical pump to force the removal of condensate.

4.5. Electric connection

Electric connection of AHU should be carried out by the qualified personnel and should be done in accordance with all standards and regulations being in force in the country where the unit is installed. The cross-section and type of cables (e.g. a shielded cable) feeding individual functional segments should be selected basing on nominal current and specific operation conditions (e.g. ambient temperature, way of cabling, distance from the power supply).

Before switching on the power supply, check conformity of voltage and frequency of a supply network with the data shown on the device's rating plate. The permissible fluctuation of the supply voltage and its frequency to the values shown on the rating plate is $\pm 5\%$. If a discrepancy exists, the device must not be connected.

4.6. Fan sets

Fan sets can be supplied with AC or EC motor, depend on the choose option and AHU selection. Fans' motors are adapted to operate in a dusty and humid environment and their insulation (F-class) is adapted to cooperate with the frequency converter. No additional means inuring the motor against conditions of the AHU fans' section are required.

Table 4. Technical data of fan sets

Unit Size	FAN Model	AC Motor								
		Rated Output	Poles	Efficiency Class	Protection Grade	Rated Current at				
						415V/3ph /50Hz	230V/1ph /50Hz	380V/3ph /50Hz	400V/3ph /50Hz	400V/3ph /60Hz
[-]	[-]	[kW]	[-]	[-]	[-]	[A]	[A]	[A]	[A]	[A]
SVS-35	VS 315	1,5	2	IE2	IP55 / F	3,1	5,54	3,36	3,1	3,19
SVS-50	VS 355	1,5	2	IE2	IP55 / F	3,1	5,54	3,36	3,1	3,19
SVS-70	VS 315 x 2	1,5 x 2	2	IE2	IP55 / F	6,2	11,08	6,72	6,2	6,38
SVS-85	VS 400 x 2	1,5 x 2	2	IE2	IP55 / F	6,2	11,08	6,72	6,2	6,38
SVS-100	VS 400 x 2	1,5 x 2	2	IE2	IP55 / F	6,2	11,08	6,72	6,2	6,38

Unit Size	FAN Model	EC Motor			
		Rated Output	Efficiency Class	Protection Grade	Rated Current at 230V/1ph/50Hz
[-]	[-]	[kW]	[-]	[-]	[A]
SVS-35	VS 315	0,75	IE4	IP54 / F	3,7
SVS-50	VS 315	0,75	IE4	IP54 / F	3,7
SVS-70	VS 315 x 2	0,75 x 2	IE4	IP54 / F	7,2
SVS-85	VS 315 x 2	0,75 x 2	IE4	IP54 / F	7,2
SVS-100	VS 315 x 2	0,75 x 2	IE4	IP54 / F	7,2



Attention: before connecting the fan set one should check carefully the rated parameters of both power supply and the converter's output.

One should connect the fan set by means of fault protection appropriate for the applied frequency converter. In case of powering with the use of a frequency converter it is not necessary to connect the motor's PTC protection. Overload protection is covered by the frequency converter by means of activating specified parameters and introducing the motor's rated data in accordance with the manual provided together with the frequency converter.



Attention: In the fan sections equipped with more than one fan (SVS 70-100) synchronous operation of fans should be ensured. The fan control system should be prepared in such a way so as to provide simultaneous start-up, rotary speed control and stoppage. In case of a breakdown and stoppage of one fan, the entire fan set does not fulfill its function and should be disabled.

In case of powering the motor from a frequency converter, high-frequency currents or voltage harmonic components in wiring powering the motor can generate some electromagnetic interferences. The connection between the frequency converter and motor should be using shielded cables, in accordance with guidelines outlined in the operation and maintenance manual of the frequency converter.

Before putting the device into service and after long time of storage or standstill, the resistance of insulation between the casing and winding should be determined, by applying the direct current.

Minimal value of insulation resistance for a new, renewed or repaired winding should be **10 MΩ** in relation to the ground.

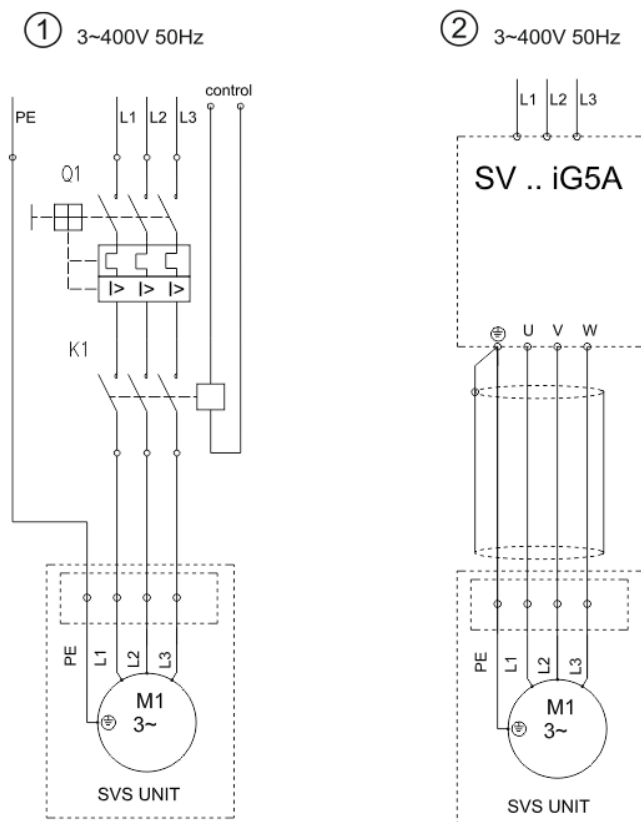

Fig.12a. Connecting diagram of the AC motor in SVS 35-50

(1) – without frequency converter 2) – with frequency converter

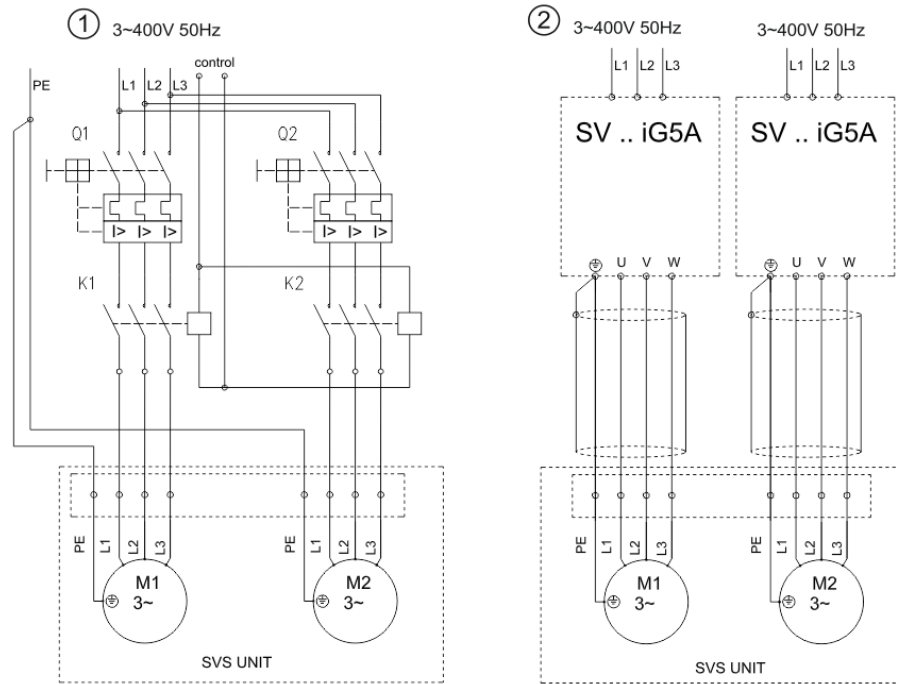

Fig.12b. Connecting diagram of the AC in SVS 70-100
(1) – without frequency converter 2) – with frequency converter

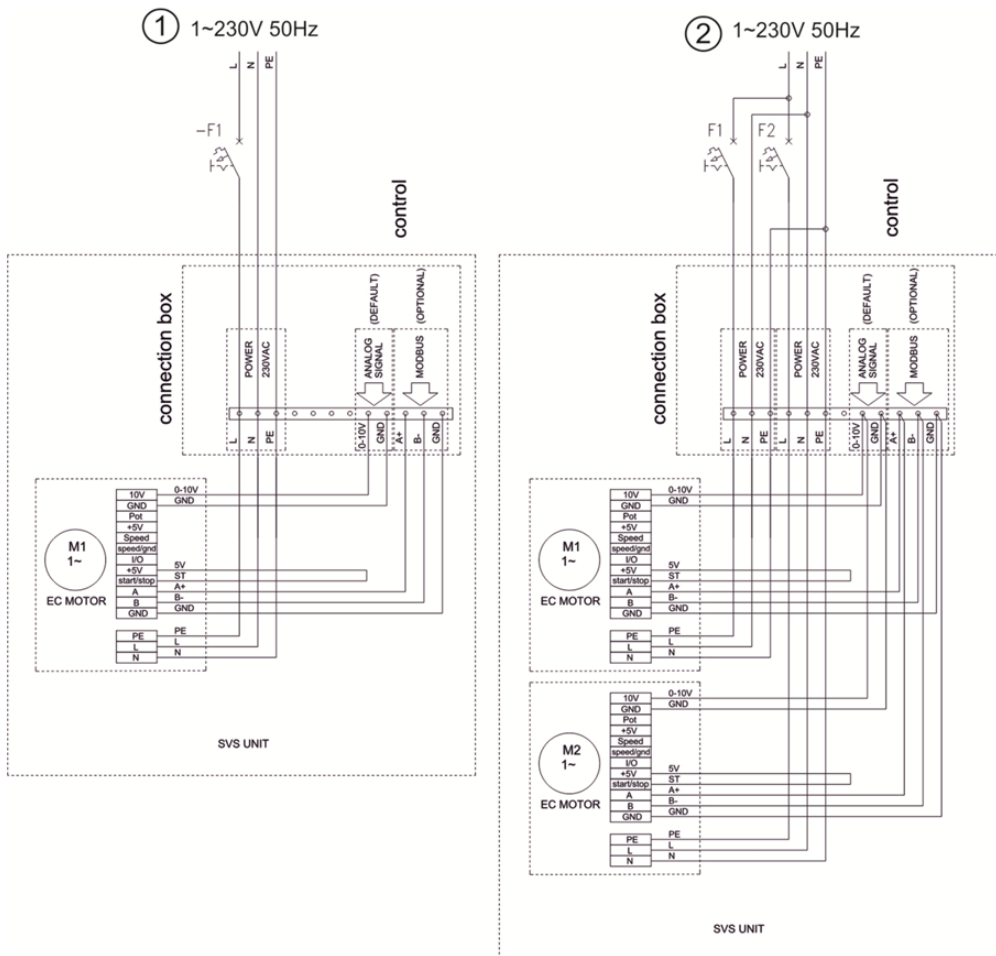

Fig.12c. Connecting diagram of the EC motor
(1) – In SVS 35-50 2) – In SVS 35-50

VTS reserves the right to implement changes without prior notice

4.7. Automatic control

A complete automatic control, which should be an integral part of each air-conditioning system, enables continuous operation of a device. In many cases it is an indispensable element and the lack of it may lead to serious operational problems or failures.

This documentation does not include information regarding the assembly of automatics, connecting, starting-up and operating of the system.

This information can be found in separate documents provided by the automatic control system supplier.

5. PREPARATION FOR START-UP

AHU start-up at putting the ventilation system into service can be carried out only by the **qualified and competent personnel**. Before the system is launched, it should be thoroughly cleaned. Check if:

- any of automatic elements or equipment were not damaged,
- all ventilation devices are mechanically installed and connected to the ventilation system,
- ground cables connecting the control gear with ventilation ducts are installed,
- hydraulic systems are fully installed and ready for operation and the cooling medium is present during the start-up,
- electric devices are wired and ready for operation,
- siphons and the condensate drain-out system from drain plate are installed,
- all automatic elements are installed and wired.

5.1. Electrical system

Before closing connecting boxes of the electric devices check the following:

- basing on the appropriate electric diagrams - verify the conformity of connections,
- application of protection units for all electric devices,
- fastening of all screws and an appropriate assembly of any supporting elements and electric connections (also unused support terminals - if any),
- cables and wiring - for conformity with all relevant safety, functional, cross-section, etc. regulations,
- appropriate ground and protection systems,
- the interiors of the connecting boxes - if there are no loose or redundant cables left.

5.2. Filters

Air filters in AHU prevent dust from getting into ventilated rooms. Additional, they protect other AHU functional elements (e.g.: water exchangers) against contamination.

 **The AHU can only be operated with assembled filters.**

Before closing the filtration casing please make sure to:

- remove protective foil from filters,
- check filters' condition,
- check settings of differential pressure controls (if they are applied) which determine permissible static pressure difference qualifying a filter for replacement.

 **Permissible pressure difference for panel filters used in AHU SVS 35-100 is 150Pa**

5.3. Fan unit

 **Electric connection of the motor fan should be made before connecting the ducts, to ensure the appropriate direction of the fan rotation.**

 **Due to the fact that in the AHUs SVS 35-100 the access to the fan section is limited by a closed casing without simple inspection door, all checking activities should be done before the duct installation.**

Check if:

- the fan's rotor rotates freely, without any friction against the casing elements,
- ground and protection connection are done correctly,
- all dampers on the ventilation ducts network are set in accordance with the design,
- the rotor rotation direction is the same as a direction of the arrow placed on the fan's casing (switch on the fan by pulsing). If they are arranged in different directions, interchange any two phases in the motor connection box or change the rotation direction on the frequency converter.

 **Access to the fan assembly is possible via revision hole after unscrewing screws around the revision panel frame.**

6. START-UP AND ADJUSTMENT

During the start-up it is possible to verify whether the AHU was made in accordance with the design and is ready for operation.

The start-up and the adjustment of the ventilation/air-conditioning systems can be done only by the qualified and competent personnel, equipped with necessary test devices.

After completing the activities described in point 5, you can proceed with the first start-up.

The fan should be started with lower load and lead towards parameters similar to the operational ones. The lower load can be achieved by closing the damper to on the AHU inlet and additionally, in case of powering the motor through the frequency converter, by lowering the rotation speed.

While increasing the load, check all the time the amount of current consumed by the motor.



Always make sure that the current intensity powering the fan's motor does not exceed the rated value for the given air parameters.

Neglecting to comply with the recommendations concerning the first start-up can lead to the motor's overload and its damage.

After the start-up, check if:

- there are no suspicious noises or unnatural mechanical sounds,
- there are no considerable AHU vibrations.



It is recommended to ensure a preliminary opening of damper on AHU inlet in the automatics system before starting up the fan. It has an impact on the damper durability and operations and eliminates the activation of pressure control.

Achieving the required performance of the AHU depends, among other factors, on the adjustment to the recommendations and the test measurements.

6.1. Measurement of the air quantity and AHU output adjustment.

Measurement of air quantity is a primary measurement in case of:

- AHU start-up and technical acceptance,
- a situation when the system does not operate in line with the requirements and expectations,
- a periodic control of AHU operations and performance,
- a replacement of fan unit elements.

Before beginning the measurements and adjustments, make sure to:

- check if the damper has been adjusted to the recommended parameters at all air grilles.
- measure the amount of current consumed by the fan's motor. If it is necessary, minimize the air flow with the main damper or reduce the fan rotation speed.

Quantitative determination of the air volume meters is based on the measurement of the average air-flow speed in the ventilation duct test cross-section. One of the most common ways of determining the average speed is the cross-section probing method with use of the Prandtl tube and the measurement of the speed-related average dynamic pressure.

Crucial factors affecting the measurement accuracy are:

- the location of the measured cross-section in relation to the other elements,
- the quantity and location of test points in the measured cross-section,
- the stability and constancy of the air flow.

It is highly recommended NOT to locate the measurement cross-section directly after:

- network elements causing deformation of the velocity speed (knees, reductions, three-way connections, dampers, etc.),
- the fan, because in the cross-section some reverse speed may occur.

The measurement should be carried out at the duct's fragment with parallel walls and straight segments at least 6 times longer than the duct diameter or equivalent diameters before the test point and not less than 3 diameters after it. In the real ventilation system finding such a long straight fragment can be a problem. In such a case determine the measurement cross-section in a place where the smallest distortions of the air-flow are expected and intensify a network of test points. The location of the measurement cross-section should be determined on the system design stage. Detailed recommendations concerning the air-flow measurement and the location of the test points are defined by the ISO 5221 standard.

We estimate the output is considered to be sufficient unless it differs more than $\pm 10\%$ from the recommended one. In case of bigger disproportions, the output matching the recommended one can be achieved by:

- an adjustment of the ventilation ducts network,
- changing the adjustment of the main damper,
- changing the fan rotary speed.

While increasing the fan's rotary speed you must by all means control the motor's power consumption and not allow to exceed the recommended rated current value. For durability and permissible operation parameters it is also very important not to exceed the maximal rotor speed. In justified situations, when there is a need to increase the air-flow output, it is recommended to use a more powerful fan's motor.

In systems equipped with dampers which automatically change the ratio of fresh, recycled and exhausted air or the by-pass flow ratio, output measurements and the main damper adjustment should be carried out in the end setting position. Next check the air ratio and the overall output in the other end position and, if necessary, carry out appropriate adjustments in order to achieve proper ration at constant overall output.

6.1. Cooler performance adjustment

Adjustment of the cooler performance should be carried out in conditions similar to the rated ones.

The temperature of the cooling agent is controlled in this way as well. If the cooler operation effect is not satisfactory, an appropriate adjustment is required. It can be carried out using the following methods:

- an adjustment of the cooling medium amount (water coolers),
- an adjustment of the air amount passing through the AHU (water cooler),

Coolers operate in most cases in complex air-conditioning systems equipped with an automatic control. Automatic control devices should be tested not only in extreme conditions but also in intermediate cooler load circumstances.

7. OPERATION AND MAINTENANCE



Personnel in charge of AHU operation should read through this documentation before starting any operation and maintenance activities. When no such personnel with appropriate skills and competence is available, periodic inspections should be carried out by the authorized VTS service providers.



Any damages of the AHU or its parts resulting from not following the guidelines stated in this documentation will not be subject to warranty claims.

Basic AHU technical data such as type, parameters and dimensions of the most significant parts are provided in the Technical Data Card supplied with each device.



Any AHU maintenance operations should be carried out with the device turned off. In order to ensure safe device operation, a service switch cutting off power supply to the motor during service operation must be installed outside the fan section. Switching off the power circuit with the service switch must be done in the non-voltage state. The service switch should be located close to the inspection panels of the fan section.

Thorough and regular maintenance, as well as technical inspections of the AHU and its components, are necessary in order to detect the failures at an early stage - before more serious damages appear.

This documentation includes only general guidelines regarding control periods, which ensure error-free operation of the AHU due to various possible external conditions. Control periods must be adjusted to the local conditions (contamination, number of start-up cycles, load, etc.).

VTS reserves the right to implement changes without prior notice

The personnel in charge of the AHU should maintain up-to-date records after the initial AHU start-up, following the guidelines in of the "Inspections and maintenance table" - which is Included in the Warranty Card. Any routine works related to the AHU operations should be recorded there. Carefully kept register is the only reliable document stating the unit operation conditions, dates of current inspections, identified problems, etc. When contacting VTS representatives always use the AHU factory identification number, located on the casing as well as in the AHU documentation.

Duration of periods between particular actions have been determined with assumption that the AHU works "non-stop" in low-dust environment and is not affected by any other factors worsening the operation conditions. In environments with a high level of dust in supply or exhaust air, the inspections should be carried out more frequently.

AHU spare parts and accessories can be ordered at local **authorized VTS service provider**. While ordering the parts please use the type and factory identification number of the device. This information can be found on the rating plate located on the fan section.

7.1. Dampers

If the damper is contaminated and does not operate smoothly, it should be cleaned in one of the following ways:

- with industrial vacuum cleaner with soft suction nozzle,
- blow it through with compressed air,
- wash it with water under pressure with cleaning agents which do not cause aluminum corrosion.

7.2. Filters

In standard AHU operation conditions the filters should be replaced circa twice a year. The necessity of replacing the filter (beside the visual contamination) is also indicated by a pressure drop (150Pa).

The AHUs are equipped with the P.FLT preliminary panel filters, G4 class.

If the final pressure difference exceeds the designed value, the filters must be replaced. Panel filters are disposable elements. When replacing the filters, also clean the filtration casing - by vacuum or dry cleaning.

In case of ordering a new filter set at the VTS authorized service provider, provide filter type, filtration class, AHU size and, if needed, size and number of filters according to the following table.

Table 6. Panel filters used in AHU SVS 35-100

AHU size	Number of panel filters P.FLT G 4 for a filtration section	
	Size	Amount
	AxB	pcs
SVS-35	549x480	2
SVS-50	619x545	2
SVS-70	969x480	2
SVS-85	646x605	3
SVS-100	712x605	3

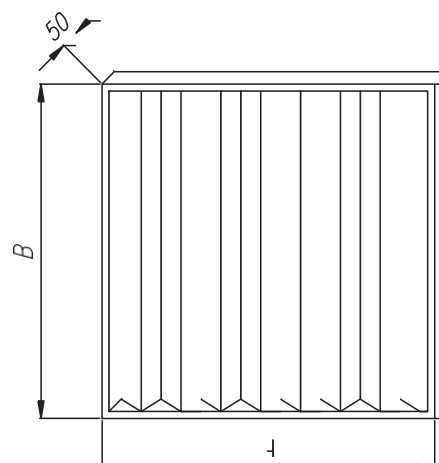

The AHUs always have to operate with installed air filters, otherwise fans' power consumption may exceed the recommended values, which may lead to the damage of the motor's wiring.

7.3. Cooler

Contamination level of the cooler should be checked during each replacement of the filters. If necessary, the cooler may be cleaned using vacuum cleaner with soft suction nozzle and washed with using spray disinfectant.

Some of the cleaners such as for e.g. Pro Care allows to cleaning exchangers and drain pans by rich spraying the coil or pan surface with using a low-pressure spray and wait several minutes without necessity of flushing.

 **Note! Each type of detergent should be used according to producer guidelines.**

While checking the contamination level, also check the capacity of the water siphon. The water siphon should be filled with water before starting up the AHU.

In order to achieve the maximum capacity of the water cooler, it must be well vented. Venting plugs are designed to do so and they are placed on the cooler's collectors.

The disinfection should be carry out by opening the inspection door on one or the others side of AHU.

7.4. Fan unit

Before starting any kind of service works (failure, maintenance, servicing) with AHU, especially in case of removing cover plates under the drive, please make sure if:

- the device has been properly disconnected from the power supply. It applies both to the main and the secondary circuits,
- the rotor is not rotating,
- the fan is cold and the surface temperate is safe for handling the device,
- the fan is protected against an unintended start-up.

Fans are designed for transferring dust-free or light-dusted air. They are not designed for aggressive gases, steams or heavy-dusted air. Operating the fan in an unsuitable environment can lead to the damage of bearings, corrosion, unbalanced rotor or vibrations.

The fan and motor in the unit have been designed for particular requirements and operation characteristics. Fan rotation speed is adapted so as the air stream and complete fan stress concentration were appropriate for a given ventilation system. Smaller stream of forced air results in disturbances in correct operation and leads to loss of balance of the entire ventilation system. It can be caused by:

- dust settlings on the fan's rotor blades,
- an incorrect direction of the fan's rotations. If the centrifugal fan rotates in an incorrect direction, the air flow is carried out with significantly worsened capacity.

When the device is operated appropriately, the bearings of fans (motors) do not need to be greased.

7.5. Test measurements

Once the inspections and maintenance procedures are over, check and adjust operation parameters according to the guidelines stated in point 6.

Please report the maintenance and measurement activities in the inspections and maintenance table.

8. SAFETY INSTRUCTIONS

1. Connection and starting up the AHU should be carried out by the qualified personnel in accordance with recommended and designed regulations and guidelines regarding the operation of electric devices.
2. Under no circumstances are you allowed to connect the device to the power supply before launching the protection system.
3. Under no circumstances are you allowed to carry out repairs or maintenance works if the device is connected to the power supply.
4. The personnel operating, repairing or providing maintenance services of the AHU must be qualified and authorized to carry out these activities in line with regulations binding in the country where the AHU is assembled.
5. The AHU assembly location must be equipped with all necessary safety and fire protection equipment in line with the local regulations.

VTS reserves the right to implement changes without prior notice



9. INFORMATION

Routine inspections carried out by the qualified technical personnel or by the VTS Authorized Service Providers guarantee a long-term, reliable and failure-free operation of the device. Our service personnel is always available to accompany you during the start-up, maintenance and in case of any emergency related to the device operation.

VTS Authorized Service Providers sell spare parts and accessories for our AHUs. While ordering the parts, please provide the AHU type and size, as well as its serial number.

You can find more information regarding the network of VTS service providers at www.vtsgroup.com